

DIGITAL POTENTIOMETERS

**Largest Selection of DCPs
(Digitally Controlled Potentiometers)**

Volatile/Non-Volatile
Single/Dual/Quad

intersil™

SIMPLY SMARTER™



DIGITAL POTENTIOMETERS

DCP OVERVIEW



DCP Overview

WHAT IS A DCP?

Digitally Controlled Potentiometers are integrated circuits incorporating a resistor ladder with its associated registers, non-volatile or volatile memory, and a digital interface providing direct communication between a host and both the resistor ladder and memory.

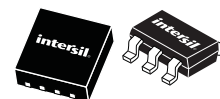

DCP Structure



Digital Control

Digital control allows the user to select each switch in a “make before break” mode, transferring the potential to the wiper.

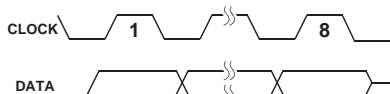

Resistor Ladder

The resistor array is comprised of individual resistors connected in series. There are electronic switches (taps) at each resistor junction, which have a common output node called a wiper (V_W/R_W). Each physical end of the array is described as a terminal and referred to as V_H/R_H and V_L/R_L, and the resistance between the terminals is referred to as R_{TOTAL}.

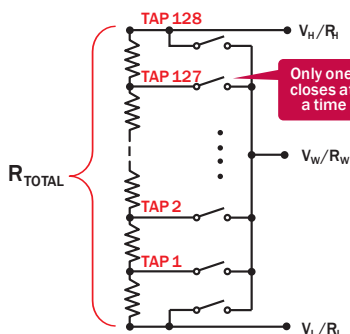

Register Store

DCP wiper position is stored in a register. When power is reset, a volatile DCP typically sets the wiper position to midscale or zero-scale at power-up. When the power is cycled for a nonvolatile DCP, the last value stored in the EEPROM register is recalled, which loads the initial wiper value during power-up.

ACCESS CONTROL REGISTER (ACR)

VOL	SHDN	WIP	0	0	0	0	0
-----	------	-----	---	---	---	---	---

DCP = Digitally Controlled Potentiometer
Tap = Switch position on resistor string
R_{TOTAL} = Total Resistance
Wiper (V_W/R_W) = DCP output node

ADVANTAGES OF DCP vs. DEVICES WITH SIMILAR FUNCTIONS

Advantage	DCP	Mechanical Potentiometer
Reliability	Not susceptible to mechanical vibration & higher tolerance to environmental factors.	Have moving parts, so can be more sensitive to vibration, humidity, etc.
Power-up	DCPs with EEPROM will store setting until user changes the value in memory (~100k to 1M times).	If glue is used to prevent wiper movement, the device setting cannot be changed.
Control	Digital control - reduced manufacturing costs and enables factory automation	Manual control - increases setup time and accuracy is reliant on technician
Size	Typically Smaller	Typically Larger
Advantage	DCP	DAC
Flexibility of Output Terminals	3 terminals allow use as either voltage divider or variable resistor. Also allows user to change voltage at terminal ends.	Terminals are usually fixed rail to rail. No flexibility to change between I _{OUT} and V _{OUT} .
Power-up Output Setting	Non-volatile DCPs have EEPROM where a user can store power-up settings.	Output typically has default settings like Volatile DCPs.
Digital Interface	Multiple Choices: I ² C, SPI, U/D, Push-button	Primarily I ² C or SPI

DIGITAL POTENTIOMETERS

DCP APPLICATIONS

DCP Applications

DCPs ENABLE DIGITALLY CONTROLLED ANALOG SIGNAL PROCESSING

DCPs allow for digital flexibility in an analog circuit. DCPs provide a link between the digital and analog domains in the system, allowing repeatable control and configuration of analog circuitry. This approach is typically more power-efficient than computationally intensive digital signal processing. For more information, please see AN133.

DIGITALLY PROGRAMMABLE

- Voltage Amplifier
- Filter
- Voltage Reference
- Voltage Regulator

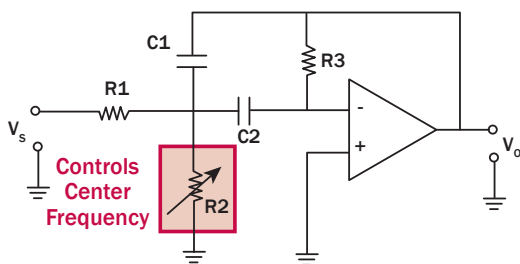

Tunable Bandpass Filter IGMF Model

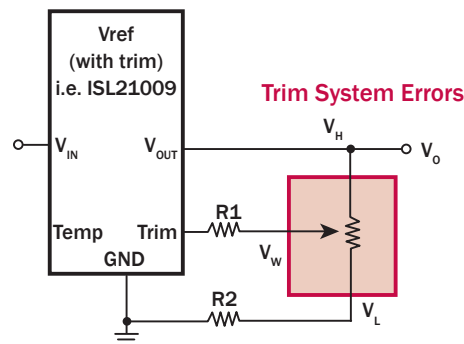

Trimmable Voltage Reference

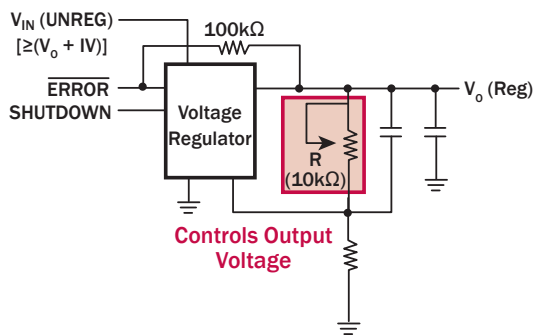

Programmable Voltage Regulator

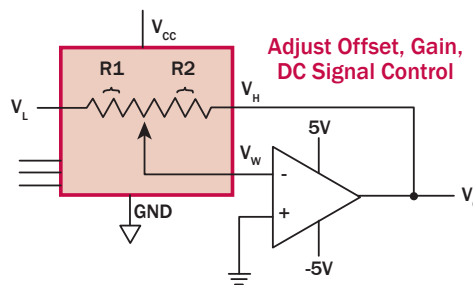

Programmable Inverting Amplifier

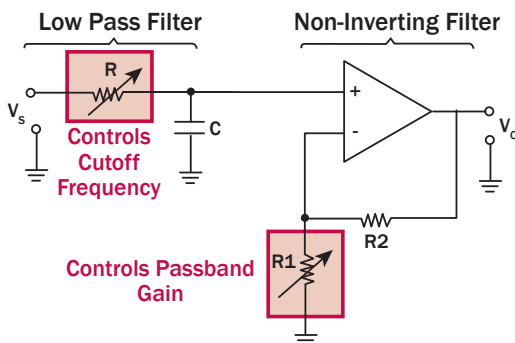

Programmable Filter and Gain Block

DIGITAL POTENTIOMETERS

FEATURED INTERSIL DCPs



Single, Non-Volatile

ISL96017

SMALLEST DCP WITH 16kBITs EXTRA MEMORY

ISL96017 – Tiny 3x3 TDFN Package

KEY FEATURES AND BENEFITS

- Save space/cost by eliminating EEPROM chip
- Integrate additional intelligence

APPLICATIONS

- Store multiple start-up values

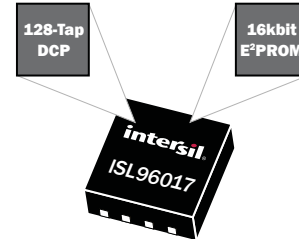

Quad, Non-Volatile

ISL22346

FIRST 125 °C NON-VOLATILE DCP

ISL22346 – Tiny Quad DCP in 4x4 TQFN Package

KEY FEATURES AND BENEFITS

- 128-tap, non-volatile, set & forget
- Save power with its shutdown feature

APPLICATIONS

- Bias control
- Calibrate for extreme environments

PACKAGE AND TEMPERATURE OPTION

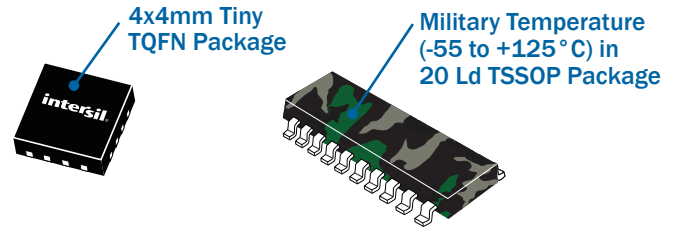

See also: ISL95811, ISL22511/12, ISL223x3/4x4

Single, Non-Volatile

ISL22317

1st LOW VOLTAGE PRECISION DCP

ISL22317 – Typically >99% Accurate at Each Tap

KEY FEATURES AND BENEFITS

- Eliminates additional calibration
- Temperature drift reduction – mirrors the temperature coefficient of the external reference resistor

APPLICATIONS

- Set specific current and resistor values

99% ACCURACY

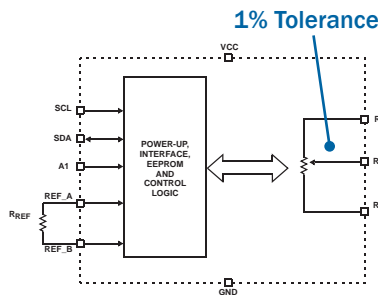

TRUE DIGITAL RHEOSTAT

Known accuracy allows for precise settings.

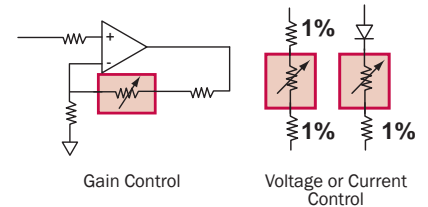

Single, Volatile

ISL22511/12

SMALLEST NON VOLATILE PUSH-BUTTON DCP

ISL22511/12 – 2.15x1.65mm μ TQFN Package

KEY FEATURES AND BENEFITS

- Simple push-button interface - No software required
- Auto/manual store – ease of use
- Zero-compensated wiper resistance - minimizes error of use

APPLICATIONS

- Adjust volume/contrast/backlight
- Additional user feature, i.e gain control

TINY μ TQFN PACKAGE

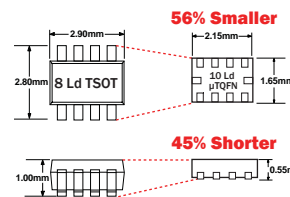

BACKLIGHT CONTROL

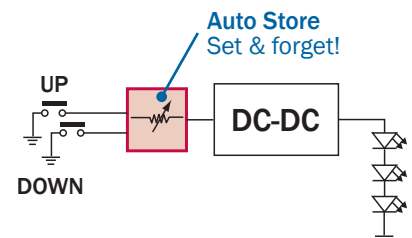

Low cost: ISL23511/ISL23512 volatile DCPs also available

DIGITAL POTENTIOMETERS

LARGEST SELECTION OF DIGITAL POTENTIOMETERS



Single DCPs

Device	Number of Taps	Memory Type	Bus Interface Type	Resistance Options (kΩ)	V _{CC} Range (V)	Terminal Voltage Range (V)	Resistance Taper	Standby Current I _{SB} (μA)	Package
Non-Volatile									
X9116	16	Non-Volatile	3-Wire (Up/Down)	10	2.7 to 5.5	0 to V _{CC}	Linear	1	8 Ld MSOP, 8 Ld SOIC
ISL22512	16	Non-Volatile	Push Button	10	2.7 to 5.5	0 to V _{CC}	Linear	0.6	10 Ld μTQFN
X9511	32	Non-Volatile	Push Button	10	4.5 to 5.5	-5.0 to +5.0	Linear	200	8 Ld PDIP, 8 Ld SOIC
X9313	32	Non-Volatile	3-Wire (Up/Down)	1, 10, 50	3.0 to 5.5	-5.0 to +5.0	Linear	500	8 Ld MSOP, 8 Ld PDIP, 8 Ld SOIC
X9314	32	Non-Volatile	3-Wire (Up/Down)	10	3.0 to 5.5	-5.0 to +5.0	Logarithmic	500	8 Ld MSOP, 8 Ld PDIP, 8 Ld SOIC
X9315	32	Non-Volatile	3-Wire (Up/Down)	10, 50, 100	2.7 to 5.5	0 to V _{CC}	Linear	1	8 Ld MSOP, 8 Ld PDIP, 8 Ld SOIC
X93154	32	Non-Volatile	3-Wire (Up/Down)	50	2.7 to 3.3	0 to V _{CC}	Linear	1	8 Ld DFN, 8 Ld MSOP
X93155	32	Non-Volatile	3-Wire (Up/Down)	50	4.5 to 5.5	0 to V _{CC}	Linear	2	8 Ld MSOP
X93156	32	Non-Volatile	3-Wire (Up/Down)	12.5, 50	2.7 to 5.5	0 to V _{CC}	Linear	1	8 Ld MSOP
ISL22511	32	Non-Volatile	Push Button	10, 50	2.7 to 5.5	0 to V _{CC}	Linear	0.6	8 Ld SOIC, 10 Ld μTQFN
X9420	64	Non-Volatile	SPI	2.5, 10	2.7 to 5.5	-5.5 to +5.5	Linear	1	14 Ld TSSOP, 16 Ld PDIP, 16 Ld SOIC
X9421	64	Non-Volatile	SPI	2.5, 10	2.7 to 5.5	0 to V _{CC}	Linear	1	14 Ld TSSOP, 16 Ld SOIC, 18 Ld PDIP
X9428	64	Non-Volatile	2-Wire	2.5, 10	2.7 to 5.5	-5.5 to +5.5	Linear	1	14 Ld TSSOP, 16 Ld PDIP, 16 Ld SOIC
X9429	64	Non-Volatile	2-Wire	2.5, 10	2.7 to 5.5	0 to V _{CC}	Linear	5	14 Ld TSSOP, 16 Ld SOIC, 18 Ld PDIP
X9317	100	Non-Volatile	3-Wire (Up/Down)	1, 10, 50, 100	2.7 to 5.5	0 to V _{CC}	Linear	1	8 Ld MSOP, 8 Ld PDIP, 8 Ld SOIC, 8 Ld TSSOP
X9318	100	Non-Volatile	3-Wire (Up/Down)	10	4.5 to 5.5	0 to +8	Linear	300	8 Ld PDIP, 8 Ld SOIC
X9319	100	Non-Volatile	3-Wire (Up/Down)	10, 50	4.5 to 5.5	0 to +10	Linear	300	8 Ld PDIP, 8 Ld SOIC
X9C102	100	Non-Volatile	3-Wire (Up/Down)	1	4.5 to 5.5	-5.0 to +5.0	Linear	750	8 Ld Other, 8 Ld PDIP, 8 Ld SOIC
X9C103	100	Non-Volatile	3-Wire (Up/Down)	10	4.5 to 5.5	-5.0 to +5.0	Linear	750	8 Ld PDIP, 8 Ld SOIC
X9C104	100	Non-Volatile	3-Wire (Up/Down)	100	4.5 to 5.5	-5.0 to +5.0	Linear	750	8 Ld PDIP, 8 Ld SOIC
X9C303	100	Non-Volatile	3-Wire (Up/Down)	32	4.5 to 5.5	-5.0 to +5.0	Logarithmic	750	8 Ld PDIP, 8 Ld SOIC, 8 Ld TSSOP
X9C503	100	Non-Volatile	3-Wire (Up/Down)	50	4.5 to 5.5	-5.0 to +5.0	Linear	750	8 Ld PDIP, 8 Ld SOIC
ISL22316	128	Non-Volatile	I ² C	10, 50	2.7 to 5.5	0 to V _{CC}	Linear	5	10 Ld MSOP
ISL22317	128	Non-Volatile	I ² C	10, 50, 100	2.7 to 5.5	0 to V _{CC}	Linear	500	10 Ld TDFN
ISL22319	128	Non-Volatile	I ² C	10, 50	2.7 to 5.5	0 to V _{CC}	Linear	850	8 Ld MSOP
ISL22416	128	Non-Volatile	SPI	10, 50	2.7 to 5.5	0 to V _{CC}	Linear	5	10 Ld MSOP
ISL22419	128	Non-Volatile	SPI	10, 50	2.7 to 5.5	0 to V _{CC}	Linear	850	8 Ld MSOP
ISL95310	128	Non-Volatile	3-Wire (Up/Down)	10, 50	2.7 to 5.5	0 to +13.2	Linear	2	10 Ld MSOP
ISL95311	128	Non-Volatile	I ² C	10, 50	2.7 to 5.5	0 to +13.2	Linear	2	10 Ld MSOP
ISL95710	128	Non-Volatile	3-Wire (Up/Down)	10, 50	2.7 to 5.5	-5.0 to +5.0	Linear	0.5 (typ)	10 Ld MSOP
ISL95711	128	Non-Volatile	I ² C	10, 50	2.7 to 5.5	-5.0 to +5.0	Linear	0.5 (typ)	10 Ld MSOP
ISL96017	128	Non-Volatile	I ² C	10, 50	3.0 to 3.6	0 to V _{CC}	Linear	10	8 Ld DFN
X9271	256	Non-Volatile	SPI	50, 100	2.7 to 5.5	0 to V _{CC}	Linear	5	14 Ld TSSOP
X9279	256	Non-Volatile	2-Wire	50, 100	2.7 to 5.5	0 to V _{CC}	Linear	5	14 Ld TSSOP, 18 Ld PDIP
ISL22313	256	Non-Volatile	I ² C	10, 50, 100	2.25 to 5.5	-5.5 to +5.5	Linear	2.5	10 Ld MSOP
ISL22414	256	Non-Volatile	SPI	10, 50, 100	2.25 to 5.5	-5.5 to +5.5	Linear	2.5	10 Ld MSOP
ISL95810	256	Non-Volatile	I ² C	10, 50	2.7 to 5.5	0 to V _{CC}	Linear	5	8 Ld DFN, 8 Ld MSOP
ISL95811	256	Non-Volatile	I ² C	10, 50	2.7 to 5.5	0 to V _{CC}	Linear	10	8 Ld DFN, 8 Ld MSOP
X9110	1024	Non-Volatile	SPI	100	2.7 to 5.5	-5.0 to +5.0	Linear	3	14 Ld TSSOP
X9111	1024	Non-Volatile	SPI	100	2.7 to 5.5	0 to V _{CC}	Linear	3	14 Ld TSSOP
X9118	1024	Non-Volatile	2-Wire	100	2.7 to 5.5	-5.0 to +5.0	Linear	3	14 Ld TSSOP
X9119	1024	Non-Volatile	2-Wire	100	2.7 to 5.5	0 to V _{CC}	Linear	3	14 Ld TSSOP
Volatile									
ISL23512	16	Volatile	Push Button	10	2.7 to 5.5	0 to V _{CC}	Linear	0.6	10 Ld μTQFN
X9015	32	Volatile	3-Wire (Up/Down)	10, 50	2.7 to 5.5	0 to V _{CC}	Linear	1	8 Ld MSOP, 8 Ld PDIP, 8 Ld SOIC
ISL23511	32	Volatile	Push Button	10, 50	2.7 to 5.5	0 to V _{CC}	Linear	0.6	8 Ld SOIC, 10 Ld μTQFN
ISL90460	32	Volatile	2-Pin (Up/Down)	10, 50, 100	2.7 to 5.5	0 to V _{CC}	Linear	1	5 Ld SC-70, 5 Ld SOT-23
ISL90461	32	Volatile	2-Pin (Up/Down)	10, 50, 100	2.7 to 5.5	0 to V _{CC}	Linear	1	6 Ld SC-70, 6 Ld SOT-23
ISL90462	32	Volatile	2-Pin (Up/Down)	10, 50, 100	2.7 to 5.5	0 to V _{CC}	Linear	1	6 Ld SC-70, 6 Ld SOT-23
ISL23710	128	Volatile	3-Wire (Up/Down)	10, 50	2.7 to 5.5	-5.5 to +5.5	Linear	0.5	10 Ld MSOP
ISL23711	128	Volatile	I ² C	10, 50	2.7 to 5.5	-5.5 to +5.5	Linear	0.5	10 Ld MSOP
ISL90726	128	Volatile	I ² C	10, 50	2.7 to 5.5	0 to V _{CC}	Linear	0.5	6 Ld SC-70
ISL90727	128	Volatile	I ² C	10, 50	2.7 to 5.5	0 to V _{CC}	Linear	0.5	6 Ld SC-70
ISL90728	128	Volatile	I ² C	10, 50	2.7 to 5.5	0 to V _{CC}	Linear	0.5	6 Ld SC-70
ISL90810	256	Volatile	I ² C	10, 50	2.7 to 5.5	0 to V _{CC}	Linear	5	8 Ld MSOP
ISL23315	256	Volatile	I ² C	10, 50, 100	1.7 to 5.5, V _{LOGIC} 1.2	0 to V _{CC}	Linear	<2.5	10 Ld MSOP, 10 μTQFN
ISL23415	256	Volatile	SPI	10, 50, 100	1.7 to 5.5, V _{LOGIC} 1.2	0 to V _{CC}	Linear	<2.5	10 Ld MSOP, 10 μTQFN

DIGITAL POTENTIOMETERS

LARGEST SELECTION OF DIGITAL POTENTIOMETERS



Dual DCPs

Device	Number of Taps	Memory Type	Bus Interface Type	Resistance Options (kΩ)	V _{CC} Range (V)	Terminal Voltage Range (V)	Resistance Taper	Standby Current I _{SB} (μA)	Package
Non-Volatile									
X93254	32	Non-Volatile	3-Wire (Up/Down)	50	2.7 to 3.3	0 to V _{CC}	Linear	1	14 Ld TSSOP
X93255	32	Non-Volatile	3-Wire (Up/Down)	50	4.5 to 5.5	0 to V _{CC}	Linear	4	14 Ld TSSOP
X93256	32	Non-Volatile	3-Wire (Up/Down)	12.5, 50	2.7 to 5.5	0 to V _{CC}	Linear	1	14 Ld TSSOP
X9221A	64	Non-Volatile	2-Wire	2, 10, 50	4.5 to 5.5	-3.0 to +5.0	Linear	500	20 Ld PDIP, 20 Ld SOIC
X9418	64	Non-Volatile	2-Wire	2.5, 10	2.7 to 5.5	-5.5 to +5.5	Linear	1	24 Ld PDIP, 24 Ld SOIC, 24 Ld TSSOP
X9410	64	Non-Volatile	SPI	10	2.7 to 5.5	-5.5 to +5.5	Linear	1	24 Ld PDIP, 24 Ld SOIC, 24 Ld TSSOP
ISL22326	128	Non-Volatile	I ² C	10, 50	2.7 to 5.5	0 to V _{CC}	Linear	5	14 Ld TSSOP
ISL22329	128	Non-Volatile	I ² C	10, 50	2.7 to 5.5	0 to V _{CC}	Linear	850	10 Ld MSOP
ISL22426	128	Non-Volatile	SPI	10, 50	2.7 to 5.5	0 to V _{CC}	Linear	5	14 Ld TSSOP
ISL22429	128	Non-Volatile	SPI	10, 50	2.7 to 5.5	0 to V _{CC}	Linear	850	10 Ld MSOP
X9268	256	Non-Volatile	2-Wire	50, 100	2.7 to 5.5	-5.5 to +5.5	Linear	5	24 Ld SOIC, 24 Ld TSSOP
X9269	256	Non-Volatile	2-Wire	50, 100	2.7 to 5.5	0 to V _{CC}	Linear	5	24 Ld SOIC, 24 Ld TSSOP
X95820	256	Non-Volatile	I ² C	10, 50	2.7 to 5.5	0 to V _{CC}	Linear	5	14 Ld TSSOP
X9260	256	Non-Volatile	SPI	50, 100	2.7 to 5.5	-5.5 to +5.5	Linear	5	24 Ld SOIC, 24 Ld TSSOP
X9261	256	Non-Volatile	SPI	50, 100	2.7 to 5.5	0 to V _{CC}	Linear	5	24 Ld SOIC, 24 Ld TSSOP
ISL22323	256	Non-Volatile	I ² C	10, 50, 100	2.25 to 5.5	-5.5 to +5.5	Linear	4	14 Ld TSSOP, 16 Ld QFN
ISL22424	256	Non-Volatile	SPI	10, 50, 100	2.25 to 5.5	-5.5 to +5.5	Linear	4	14 Ld TSSOP, 16 Ld QFN
Volatile									
X9460	32	Volatile	2-Wire	32	2.7 to 5.5	-5.5 to +5.5	Logarithmic	3	14 Ld TSSOP
ISL22102	32	Volatile	Push button	32	2.7 to 5.5	0 to AV _{CC}	Logarithmic	395	14 Ld TSSOP, 20 Ld QFN

Quad DCPs

Device	Number of Taps	Memory Type	Bus Interface Type	Resistance Options (kΩ)	V _{CC} Range (V)	Terminal Voltage Range (V)	Resistance Taper	Standby Current I _{SB} (μA)	Package
Non-Volatile									
X9241A	64	Non-Volatile	2-Wire	2, 10, 50	4.5 to 5.5	-3.0 to +5.0	Linear	500	20 Ld PDIP, 20 Ld SOIC, 20 Ld TSSOP
X9408	64	Non-Volatile	2-Wire	2.5, 10	2.7 to 5.5	-5.5 to +5.5	Linear	1	24 Ld PDIP, 24 Ld SOIC, 24 Ld TSSOP
X9409	64	Non-Volatile	2-Wire	2.5, 10	2.7 to 5.5	0 to V _{CC}	Linear	1	24 Ld SOIC, 24 Ld TSSOP
X9400	64	Non-Volatile	SPI	2.5, 10	2.7 to 5.5	-5.5 to +5.5	Linear	1	24 Ld PDIP, 24 Ld SOIC, 24 Ld TSSOP
X9401	64	Non-Volatile	SPI	2.5, 10	2.7 to 5.5	0 to V _{CC}	Linear	1	24 Ld PDIP, 24 Ld SOIC, 24 Ld TSSOP
ISL22346	128	Non-Volatile	I ² C	10, 50	2.7 to 5.5	0 to V _{CC}	Linear	5	20 Ld TSSOP
ISL22349	128	Non-Volatile	I ² C	10, 50	2.7 to 5.5	0 to V _{CC}	Linear	2400	14 Ld TSSOP
ISL22446	128	Non-Volatile	SPI	10, 50	2.7 to 5.5	0 to V _{CC}	Linear	5	20 Ld TSSOP
ISL22449	128	Non-Volatile	SPI	10, 50	2.7 to 5.5	0 to V _{CC}	Linear	2400	14 Ld TSSOP
X9252	256	Non-Volatile	2-Wire, 3-Wire (Up/Down)	2, 10, 50, 100	2.7 to 5.5	0 to V _{CC}	Linear	100	24 Ld TSSOP
X9258	256	Non-Volatile	2-Wire	50, 100	2.7 to 5.5	-5.5 to +5.5	Linear	5	24 Ld SOIC, 24 Ld TSSOP
X9259	256	Non-Volatile	2-Wire	50, 100	2.7 to 5.5	0 to V _{CC}	Linear	5	24 Ld SOIC, 24 Ld TSSOP
X95840	256	Non-Volatile	I ² C	10, 50	2.7 to 5.5	0 to V _{CC}	Linear	5	20 Ld TSSOP
X9250	256	Non-Volatile	SPI	50, 100	2.7 to 5.5	-5.5 to +5.5	Linear	5	24 Ld SOIC, 24 Ld TSSOP
X9251	256	Non-Volatile	SPI	50, 100	2.7 to 5.5	0 to V _{CC}	Linear	3	24 Ld PDIP, 24 Ld SOIC, 24 Ld TSSOP
ISL22343	256	Non-Volatile	I ² C	10, 50, 100	2.25 to 5.5	-5.5 to +5.5	Linear	4	20 Ld QFN, 20 Ld TSSOP
ISL22444	256	Non-Volatile	SPI	10, 50, 100	2.25 to 5.5	-5.5 to +5.5	Linear	4	20 Ld QFN, 20 Ld TSSOP
Volatile									
ISL90840	256	Volatile	I ² C	10, 50	2.7 to 5.5	0 to V _{CC}	Linear	5	20 Ld TSSOP
ISL90841	256	Volatile	I ² C	10, 50	2.7 to 5.5	0 to V _{CC}	Linear	5	14 Ld TSSOP
ISL90842	256	Volatile	I ² C	10, 50	2.7 to 5.5	0 to V _{CC}	Linear	5	14 Ld TSSOP
ISL90843	256	Volatile	I ² C	10, 50	2.7 to 5.5	0 to V _{CC}	Linear	2800	10 Ld DFN, 10 Ld MSOP

INTERSIL DCP QUICK REFERENCE

Non-Volatile (EEPROM Memory)

<ul style="list-style-type: none"> → Single 16-Tap (4-Bits) X9116 - 10kΩ, Up-Down ISL22512 - 10kΩ, Push Button → Single 32-Tap (5-Bits) ☐ X9313 - 1kΩ / 10kΩ / 50kΩ, Up-Down ☐ X9314 - 10kΩ, Log Taper, Up-Down X9315 - 10kΩ / 50kΩ / 100kΩ, Up-Down X93154 - 50kΩ, Up-Down, 2-Terminal X93155 - 50kΩ, Up-Down, 2-Terminal X93156 - 12.5kΩ / 50kΩ, Up-Down ☐ X9511 - 1kΩ / 10kΩ, Push Button ISL22511 - 10kΩ / 50kΩ, Push Button → Single 64-Tap (6-Bits) X9429 - 2.5kΩ / 10kΩ, 2-Wire → Single 100-Tap (~6.65-Bits) X9317 - 1kΩ / 10kΩ / 50kΩ / 100kΩ, Up-Down ☐ X9318 - 10kΩ, Up-Down ☐ X9319 - 10kΩ / 50kΩ / 100kΩ, Up-Down ☐ X9C102 - 1kΩ, Up-Down ☐ X9C103 - 10kΩ, Up-Down ☐ X9C104 - 100kΩ, Up-Down ☐ X9C503 - 50kΩ, Up-Down ☐ X9C303 - 32kΩ, Log Taper, Up-Down → Single 128-Tap (7-Bits) ISL22316 - 10kΩ / 50kΩ, I²C ISL22317 - 10kΩ / 50kΩ / 100kΩ, 1% Tolerance, I²C ISL22319 - 10kΩ / 50kΩ, I²C, Wiper Only ☐ ISL95311 - 10kΩ / 50kΩ, I²C ☐ ISL95711 - 10kΩ / 50kΩ, I²C ISL96017 - 10kΩ / 50kΩ, I²C (16kbits extra EEPROM) ISL22416 - 10kΩ / 50kΩ, SPI ISL22419 - 10kΩ / 50kΩ, SPI, Wiper Only ☐ ISL95310 - 10kΩ / 50kΩ, Up-Down ☐ ISL95710 - 10kΩ / 50kΩ, Up-Down → Single 256-Tap (8-Bits) ISL95810 - 10kΩ / 50kΩ, I²C ISL95811 - 10kΩ / 50kΩ, I²C ☐ ISL22313 - 10kΩ / 50kΩ / 100kΩ, I²C ☐ ISL22414 - 10kΩ / 50kΩ / 100kΩ, SPI → Single 1024-Tap (10-Bits) ☐ X9110 - 100kΩ, SPI X9111 - 100kΩ, SPI ☐ X9118 - 100kΩ, 2-Wire X9119 - 100kΩ, 2-Wire 	<ul style="list-style-type: none"> → Dual 32-Tap (5-Bits) X93254 - 50kΩ, Up-Down, 2-Terminal X93255 - 50kΩ, Up-Down, 2-Terminal X93256 - 50kΩ, Up-Down → Dual 64-Tap (6-Bits) ☐ X9410 - 10kΩ, SPI ☐ X9221A - 2kΩ / 10kΩ / 50kΩ, 2-Wire ☐ X9418 - 2.5kΩ / 10kΩ, 2-Wire → Dual 128-Tap (7-Bits) ISL22326 - 10kΩ / 50kΩ, I²C ISL22329 - 10kΩ / 50kΩ, I²C, Wiper Only ISL22426 - 10kΩ / 50kΩ, SPI ISL22429 - 10kΩ / 50kΩ, SPI, Wiper Only → Dual 256-Tap (8-Bits) X95820 - 10kΩ / 50kΩ, I²C ☐ X9260 - 50kΩ / 100kΩ, SPI X9261 - 50kΩ / 100kΩ, SPI ☐ X9268 - 50kΩ / 100kΩ, 2-Wire ☐ ISL22323 - 10kΩ / 50kΩ / 100kΩ, I²C ☐ ISL22424 - 10kΩ / 50kΩ / 100kΩ, SPI 	<ul style="list-style-type: none"> → Quad 64-Tap (6-Bits) ☐ X9400 - 2.5kΩ / 10kΩ, SPI X9401 - 10kΩ, SPI ☐ X9241A - 2kΩ / 10kΩ / 50kΩ, 2-Wire ☐ X9408 - 2.5kΩ / 10kΩ, 2-Wire X9409 - 2.5kΩ / 10kΩ, 2-Wire → Quad 128-Tap (7-Bits) ISL22346 - 10kΩ / 50kΩ, I²C ISL22349 - 10kΩ / 50kΩ, I²C, Wiper Only ISL22446 - 10kΩ / 50kΩ, SPI ISL22449 - 10kΩ / 50kΩ, SPI, Wiper Only → Quad 256-Tap (8-Bits) X95840 - 10kΩ / 50kΩ, I²C ☐ X9250 - 50kΩ / 100kΩ, SPI X9251 - 50kΩ / 100kΩ, SPI X9252 - 2kΩ / 10kΩ / 50kΩ / 100kΩ, 2-Wire ☐ X9258 - 50kΩ / 100kΩ, 2-Wire X9259 - 50kΩ / 100kΩ, 2-Wire ☐ ISL22343 - 10kΩ / 50kΩ / 100kΩ, I²C ☐ ISL22444 - 10kΩ / 50kΩ / 100kΩ, SPI
<h3>Special Function DCPs</h3> <ul style="list-style-type: none"> → Dual Audio DCP - Integrated Output Buffer Amps and Audio Detect ISL22102 - 32kΩ, Log Taper, Push Button, 0 to -72dB Dynamic Range → Low Voltage 1% Tolerant Precision DCP & Low Temperature Coefficient ISL22317 - 10kΩ / 50kΩ / 100kΩ, I²C → Programmable Voltage Reference X60250 - Micro-power, 8-bit Adjustable, 0 to 1.25V ISL21400 - Programmable Gain and Temperature Slope → Sensor Conditioners with ADC, E²PROM Look-Up Tables, and DACs X96010 - Dual, 2-Wire X96011 - Single with Temperature Sensor, 2-Wire X96012 - Dual with Temperature Sensor, 2-Wire → Single 128-Tap DCP with 16kbits General Purpose E²PROM ISL96017 - 10kΩ / 50kΩ, I²C → TFT/LCD Programmable V_{COM} Calibrator (128 Step) ISL45041 - I²C ISL45042 - Up-Down 		

Volatile (No EEPROM Memory)

<ul style="list-style-type: none"> → Single 16-Tap (4-Bits) ISL23512 - 10kΩ, Push Button → Single 32-Tap (5-Bits) X9015 - 10kΩ / 50kΩ / 100kΩ, Up-Down ISL23511 - 10kΩ / 50kΩ, Push Button ISL90460 - 10kΩ / 50kΩ / 100kΩ, Up-Down, Rheostat ISL90461 - 10kΩ / 50kΩ / 100kΩ, Up-Down, 2-Terminal ISL90462 - 10kΩ / 50kΩ / 100kΩ, Up-Down, 2-Terminal → Single 128-Tap (7-Bits) ISL90726 - 10kΩ / 50kΩ, I²C, 2-Terminal ISL90727 - 10kΩ / 50kΩ, I²C, 2-Terminal ISL90728 - 10kΩ / 50kΩ, I²C, 2-Terminal ☐ ISL23711 - 10kΩ / 50kΩ, I²C ☐ ISL23710 - 10kΩ / 50kΩ, Up-Down → Single 256-Tap (8-Bits) ISL90810 - 10kΩ / 50kΩ, I²C ISL23315 - 10kΩ / 50kΩ / 100kΩ, I²C, Low Voltage ISL23415 - 10kΩ / 50kΩ / 100kΩ, SPI, Low Voltage 	<ul style="list-style-type: none"> → Dual 32-Tap (5-Bits) ☐ X9460 - 32kΩ, Log Taper, 2-Wire ISL22102 - 32kΩ, Log Taper, Audio Detect, Push Button 	<ul style="list-style-type: none"> → Quad 256-Tap (8-Bits) ISL90840 - 10kΩ / 50kΩ, I²C ISL90841 - 10kΩ / 50kΩ, I²C, 2-Terminal ISL90842 - 10kΩ / 50kΩ, I²C, 2-Terminal ISL90843 - 10kΩ / 50kΩ, I²C, Wiper Only
<p>☐ Extended positive terminal voltage ☐ Positive and negative terminal voltage</p>		



Intersil Main Offices

Visit www.intersil.com for a complete list of sales representatives and distributors.

NORTH AMERICA

WEST COAST
Intersil Headquarters
1001 Murphy Ranch Road
Milpitas, CA 95035
(TEL) 408-432-8888
(FAX) 408-434-5351
1-888-INTERSIL
1-888-468-3774

EAST COAST
1650 Robert J Conlan Blvd NE
Palm Bay, FL 32905
(TEL) 321-724-7000
(FAX) 321-729-7320
1-888-INTERSIL
1-888-468-3774

ASIA PACIFIC

Suite 1611, 16/F Tower 2
Silvercord, 30
Canton Road,
Tsimshatsui, Kowloon
Hong Kong
(TEL) +852-2709-7600
(FAX) +852-2730-1433

JAPAN

6F, Mita Nitto Daibiru
3-11-36, Mita, Minato-ku
Tokyo, 108-0073 Japan
(TEL) +81-3-5439-2311
(FAX) +81-3-5439-2300

EUROPE

Oskar-Messter-Str. 29
D-85737 Ismaning
Germany
(TEL) +49-89-46263-0
(FAX) +49-89-46263-148