

Introduction

The ISL21007, ISL21009 voltage references are fabricated on Intersil's proprietary Floating Gate Analog (FGA) technology and are very low power, high precision, and low noise. The reference Trim pin enables the user to adjust the output voltage up or down by 2.5%, thereby giving the flexibility to use the part for a wide range of applications.

Pinout

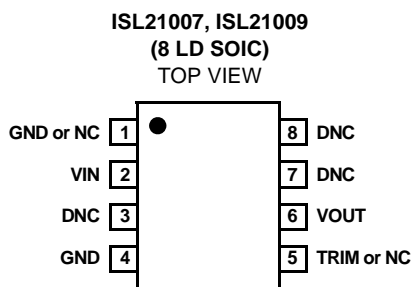

Trim Pin Circuitry

As shown in Figure 1, the Trim input is internally biased by a resistor divider, such that when the Trim pin is floating, the voltage at the pin is $V_{OUT}/2$. It can be driven externally by using a Digitally Controlled Potentiometer (DCP), such as the ISL95810. As long as the DCP resistance is significantly lower than 625k Ω , the voltage reference part can be trimmed to obtain a V_{OUT} within $\pm 2.5\%$ of the nominal value.

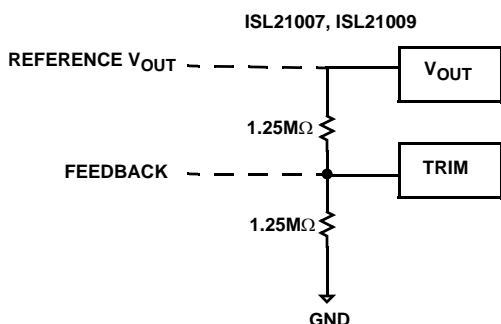

FIGURE 1. TRIM PIN CIRCUITRY

Adjusting V_{OUT} Using ISL95810

The ISL95810 DCP is low noise, and has a low power I²C bus with 256 taps and is implemented with a combination of resistor elements and CMOS switches. The position of the wiper is controlled by the user through the I²C bus interface. The potentiometer has an associated volatile Wiper Register (WR) and a non-volatile Initial Value Register (IVR) that can be directly written to and read by the user. The content of the WR controls the position of the wiper. At power-up, the device recalls the contents of the DCP's IVR to the WR. A block diagram of the ISL95810 is shown in Figure 2¹.

The high terminal of the DCP (RH) is connected to the V_{OUT} pin of the ISL21007, ISL21009, and the Wiper terminal of the DCP part (RW) is connected to the Trim pin of the reference. The Low terminal of the DCP (RL) is connected to ground. The evaluation software available with the ISL95810 evaluation parts allows the user to write to the wiper register (WR) in order to adjust the output voltage of the ISL21007, ISL21009. Ideally, the DCP resistance is approximately 10x smaller than the resistance at the Trim pin. As a result, the DCP resistance will dominate the voltage reference part and it can be externally biased to achieve the desired output voltage adjustment.

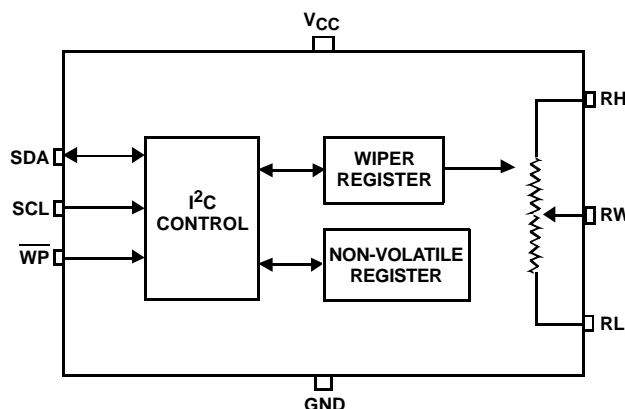

FIGURE 2. ISL95810 BLOCK DIAGRAM

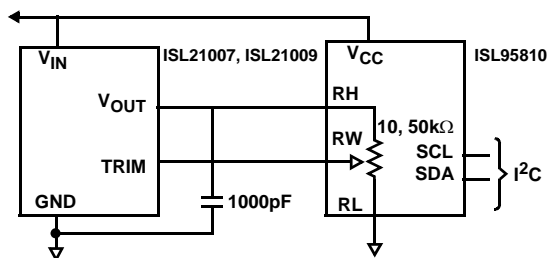

FIGURE 3. CONNECTING THE ISL21007, ISL21009 TO ISL95810

1. Intersil Corporation ISL95810 data sheet.

Figure 4 shows the variation in the output of the ISL21007-25 as the Trim pin is swept from 0 to V_{OUT} using ISL95810. The output voltage of the reference will vary up to nominal $V_{OUT} \pm 2.5\%$. The step size of the change in output voltage is $488\mu V$ due to the fact that the DCP used to adjust V_{OUT} has 256 taps and the allowed Trim is $\pm 2.5\% V_{OUT}$.

When the Trim pin voltage is $V_{OUT}/2$, the output voltage of the part is the nominal output of the part, in this case 2.50V. Also, when the trim pin is floating at room temperature, the voltage at the trim pin is half the nominal V_{OUT} as a result of the voltage divider at the Trim pin shown in Figure 1.

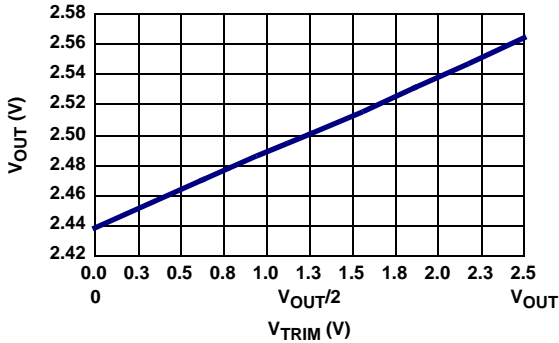

FIGURE 4. V_{OUT} (V) vs TRIM PIN VOLTAGE (V)

TABLE 1. V_{REF} (V) AS A FUNCTION OF TRIM PIN VOLTAGE (V)

TRIM PIN VOLTAGE (V)	V_{REF} (V)
0	$V_{OUT} - 2.5\% V_{OUT}^*$
$V_{OUT}/2$	V_{OUT}
V_{OUT}	$V_{OUT} + 2.5\% V_{OUT}$

* V_{OUT} indicates nominal output voltage of the voltage reference part

Effects of Trimming on Voltage Reference Temperature Coefficient

Temperature Coefficient (TC) is a measure of the output voltage change with respect to changes in the operating temperature. The TC for ISL21007, ISL21009 is low and varies from $3\text{ppm}/^\circ\text{C}$ to $10\text{ppm}/^\circ\text{C}$ for B- and D-grades respectively.

Given the parabolic shape of the TC curve, the standard for specifying the TC of a reference is the Box Method². In the box method, the reference voltage is measured throughout the temperature range from the minimum specified temperature to the maximum specified temperature as shown in Equation 1:

$$TC = \frac{(V_{REFmax} - V_{REFmin}) / (T_{max} - T_{min})}{V_{REFnominal}} \cdot 10^6 \text{ ppm}/^\circ\text{C} \quad (\text{EQ. 1})$$

The two plots in Figure 5 show the change in output voltage over temperature as the Trim pin is adjusted using the DCP. The TC for the case when the voltage reference part is connected to the DCP for V_{OUT} adjustment and when the trim pin is floating are approximately the same in value, $1.7\text{ppm}/^\circ\text{C}$. The trim pin should be left floating when no output voltage adjustment is desired.

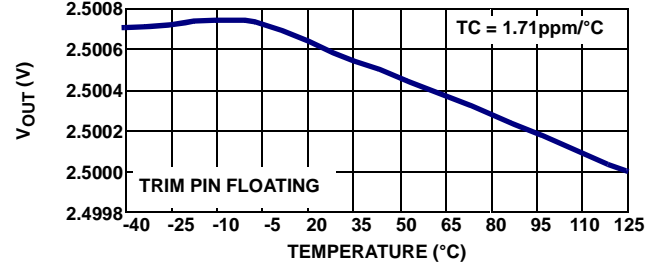
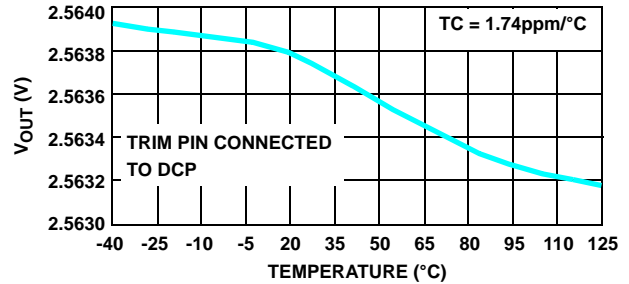

FIGURE 5. CHANGE IN OUTPUT VOLTAGE OVER TEMPERATURE AS A FUNCTION OF THE TRIM PIN CONNECTION

Conclusion

The output voltage of the ISL21007 and ISL21009 can be adjusted using the DCP without any significant change in the TC. As seen in Figure 5, even after the adjusting the output voltage, the TC of the voltage reference parts is well within the guaranteed limits of the datasheet specifications.

2. Intersil Corporation AN177 Application Note.

Intersil Corporation reserves the right to make changes in circuit design, software and/or specifications at any time without notice. Accordingly, the reader is cautioned to verify that the Application Note or Technical Brief is current before proceeding.