

# Video Coax CMV Rejection Networks

## Introduction

In NTSC and PAL video, designers often assume that the Earth ground between two locations is the same, but this may not always be the case. Older buildings may not have good grounding and a potential difference between Earth ground and the building ground may exist. This can cause interference in transmission of video signals since the reference levels and local grounds are different. The usual technique is to compensate this interference at the receiving end, but if you don't have access to the receiver, you can compensate for Common Mode Voltage (CMV) at the transmitter.

This technical brief discusses both solutions. First, the typical one at the receiver, followed by the solution if you only have access to the transmit side. We will close with a short discussion on a CMV Isolation Transformer solution capable of rejecting over  $120V_{AC}$ . (Note units used will be: CMV will be  $\pm V$ ; Video will be  $V_{p-p}$  or  $V_p$ )

## Overview of the Parts Chosen

### Receiver CMV Rejection

Common Mode Voltage (CMV) on coax cable is normally rejected at the receiver end of the cable using a differential video amplifier. At the receiver, the EL5172 differential,  $\pm 5V_{SUPPLY}$  video amp was selected as it has a good data sheet CMV range of  $7V_{p-p}$ . Yet, this CMV range will be reduced by the video input ( $1V_{p-p}$ ) to about  $6V_{p-p}$  or to an active  $\pm 3V$  CMV range.

### Transmitter CMV Rejection

In those cases where the receiver end of the cable is not available, a circuit can be used to do the CMV rejection at the transmitter end of the coax cable. The EL5260, EL5261 amplifier was selected as it has an output range of  $6.8V_{p-p}$ , closely matching the input range of the receiver (EL5172). Since the video output is  $2V_{p-p}$ , this leaves  $4.8V_{p-p}$  to compensate up to  $\pm 2.4V$  of CMV.

At the transmitter end, we will need to detect the ground difference on the coax shield and sum this with the incoming video to compensate the transmitted signal for this induced CMV. The CMV induced on the coax shield will be null out by the added CMV at the transmitter. The result is the video at the receiver end of the cable has the CMV removed and just the video signal at the receiver amplifier.

Comment: The two amps are selected so both transmitter and receiver rejection networks may be used in conjunction with one another to increase the overall CMV range to  $\pm 5.4V$ . Just ensure the receiver CMV must be equal or greater than the transmitter output range.

### Receiver CMV Rejection

As stated earlier, the receiver rejection is simpler since we can use a common differential video amplifier to remove the CMV (Figure 1). First we need to terminate the coax with the typical  $75\Omega$  termination resistor. Next, buffer the incoming video with a gain of one (or two) and impedance match the output with series  $75\Omega$  impedance. We selected the differential video amplifiers EL5172 for NTSC and EL5375 (triple version of the EL5175) for RGB.

Typically the shield on a long run of coax will pick-up noise, primarily line noise ( $60Hz/50Hz$ ), but may also pick-up some HF noise as well. The line noise is due to the transmitter local ground not being at the same potential as the receiver local ground. To separate true noise from this ground differential common mode potential, we will refer to this ground differential as Line Frequency CMV voltage or  $V_{LINECMV}$ . The received video signal will have this  $V_{LINECMV}$  added to the video signal at the output of the coax cable. This combined signal will appear as input to the ground referenced video differential amplifier, EL5172.

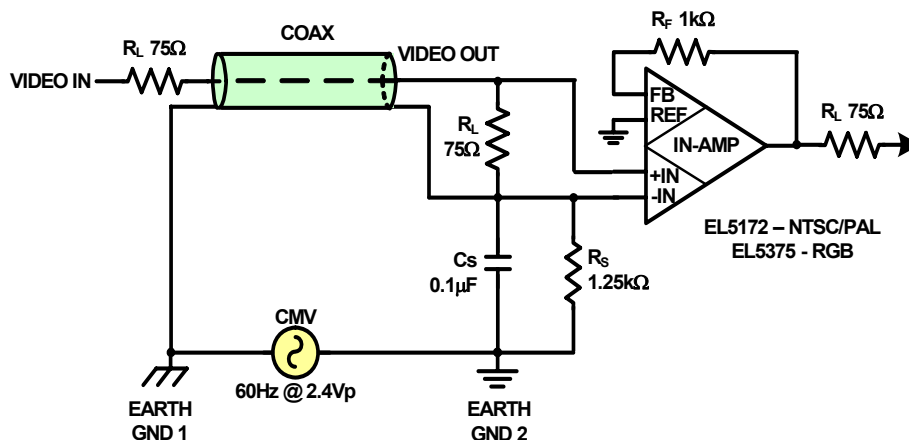

**FIGURE 1. RECEIVER CMV REJECTION CIRCUIT**

## CMV Conversion Voltage ( $V_{CONVT}$ )

The receiver solution uses a differential amplifier across the cable, allowing the CMV on the shield to have light loading. This configuration minimizes CMV conversion to the video signal. If the coax cable shield is viewed as a simple resistor ( $R_{SHIELD}$ ), the line CMV currents ( $I_{LINECMV}$ ) running through the cable shield will generate a differential voltage across the cable. This differential voltage is called CMV Conversion Voltage ( $V_{CONVT}$ ).

$$V_{CONVT} = I_{LINECMV} \times R_{SHIELD} \quad (EQ. 1)$$

Equation 1 is CMV generated by the ground differentials and is added to the video signal. Thus, you will need to keep this line CMV current to a minimum by limiting the loading.

Addressing the high frequency noise induced onto the shield is simple. As in Figure 1, a single ceramic capacitor (CS) to ground of about  $0.1\mu F$ , will short high frequency noise while not having any loading effect on the line noise.

## Reducing the $V_{LINECMV}$

If the shield is terminated through a resistor to ground,  $R_S$ , the noise voltage can be reduced by lowering the  $I_{LINECMV}$ . We cannot go directly to ground without developing the full differential ground voltage across the shield as previously stated. We cannot eliminate it but we can limit this  $I_{LINECMV}$  to where CMV conversion voltage is not noticeable on the video display.

## Determining $R_S$

The shield impedance is typically about 15 times smaller than the conductor impedance. Since the conductor is typically  $24\Omega/1kft$ , the shield impedance would be about  $1.67\Omega/1kft$ . We need to maintain maximum CMV range of  $\pm 3V$  as noted in "Receiver CMV Rejection" on page 1. It was determined, empirically, back in the B/W TV days, if less than 20mV of CMV on a 1V video signal is maintained, the CMV impact would not be visible on a display.

As previously stated in "CMV Conversion Voltage ( $V_{CONVT}$ )" on page 2, Equation 2 shows:

$$V_{CONVT} = I_{LINECMV} \times R_{SHIELD} \quad (EQ. 2)$$

Let's pick a  $V_{CONVT}$  that would not impact the signal but keep  $R_S$  small enough to suppress noise voltage, say 4mV:

$$V_{CONVT} = I_{NOISE} \times R_{SHIELD} \quad (EQ. 3)$$

$$4mV = I_{NOISE} \times 1.67\Omega$$

$$I_{LINECMV} = 2.4mA$$

$$R_S = CMV / (I_{LINECMV})$$

$$R_S = 3V / 2.4mA = 1.25k\Omega$$

The  $R_S$  shield termination is  $1.25k\Omega$  to prevent noise pick-up.

The receiver and transmitter CMV are both limited to 2.4mA if we use  $R_S = 1.25k\Omega$ . If you use both the transmitter rejection and receiver rejection circuits, then the CMV will divide proportionally to the CMV input range of both circuits. Thus, you will extend the CMV rejection range when using both the transmitter and receiver rejection circuits together.

## Transmitter CMV Rejection

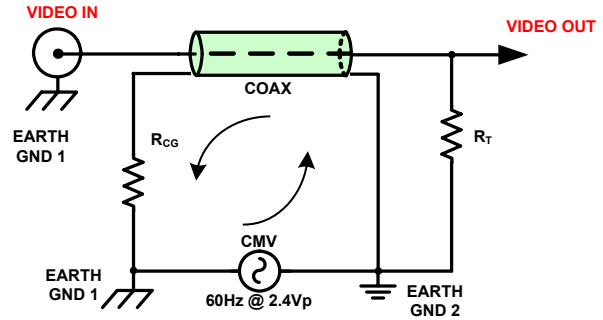

FIGURE 2. CONCEPT OF GROUND DIFFERENCE

If the system CMV can be detected at the transmitter, we can use this level to compensate and offset the video before it is sent to the receiver. Figure 2 shows a simple loop concept which places the CMV across  $R_{CG}$ . Now we can buffer this  $CMV_{RCG}$  and apply it back to the transmitting Video Amp. This will add the  $CMV_{RCG}$  to the incoming video.

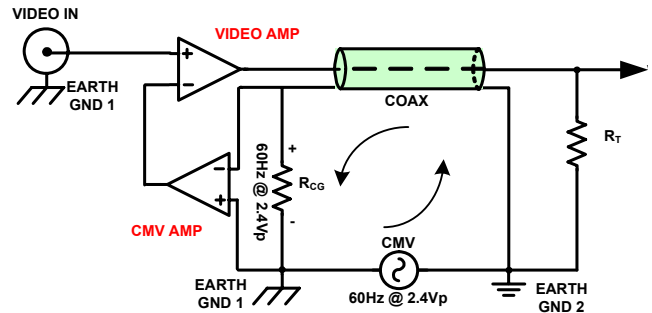

FIGURE 3. CONCEPT OF TRANSMITTER REJECTION CIRCUIT

## DETAILED TRANSMITTER CIRCUIT

For NTSC/PAL, selected were the EL5260 and EL5261, dual channel 200MHz low-power current feedback amplifiers for their bandwidth, supply range and footprint (Figure 4).

For RGB, selected were the EL5363, a triple, 500MHz bandwidth video amp, and the EL5160, a single op amp for the CMV amp (Figure 5).

This detailed discussion will be for the NTSC/PAL implementation (single op amp) as the RGB is a minor extension of the NTSC design. We will discuss those unique differences in detail in the following sections.

## NTSC/PAL Rejection Network (Figure 4)

To detect the Earth CMV and compensate the incoming video signal, we used an inverting unity gain amplifier (CMV Amp,  $A_1$ ). By generating the -CMV signal at the output of  $A_1$ , the -CMV is summed with the video input at the Video Amp stage,  $A_2$ .

NOTE:  $A_1$ 's inputs are at the local virtual ground and the output will drive to maintain this virtual ground. Thus, the system's CMV will appear across RCG.

We apply the output of  $A_1$ , -CMV, to the difference node, '-' input of  $A_2$ . This effectively inverts the -CMV to +CMV. The output of  $A_2$  is shown in Equation 4:

$$A2_{\text{OUTPUT}} = 2 \times \text{Video}_{\text{IN}} + \text{CMV} \quad (\text{EQ. 4})$$

The coax shield on the transmitter end will have the same CMV as the coax shield on the receiver end. Now, with the input to the coax being  $\text{Video}_{\text{IN}} + \text{CMV}$ , the receiver end of the coax to the shield is just the  $\text{Video}_{\text{IN}}$  with the CMV compensated.

$A_2$ 's configuration is the typical gain of 2 to overcome the output termination loss at the receiver.

The transmitter end of the cable shield should be terminated to prevent noise pick-up from a floating

shield. Since we use a unity gain buffer to detect the Line Frequency CMV voltage or  $V_{\text{LINECMV}}$ , we need to ensure the receiver CMV current termination is matched with the transmitter current termination of  $I_{\text{LINECMV}} = 2.4\text{mA}$ .

The selected EL5261 is a dual supply, dual video amp that can be used for both the CMV amplifier as well as the video amp. Since we need to balance the  $I_{\text{LINECMV}}$  at both ends, use a DC termination resistor of  $1\text{k}\Omega$  to generate a CMV within the limits at the transmitter and the receiver ends ( $\text{CMV} = \pm 2.4\text{V}$ ). The  $1\text{k}\Omega$  would also limit the current to  $2.4\text{mA}$ , preventing CMV conversion to diff signal in the shield as described previously in the "Determining  $R_S$ " section on page 2.

Thus, looking back from the transmitter end of the coax shield, the impedance must be  $1\text{k}\Omega$ . Since  $A_1$ 's input is at the local ground, you have RCG of  $1\text{k}\Omega$  to ground and the shield source to ground. Thus, an additional  $R_S$  is not needed and is left open. For AC termination and HF filtering, we used a standard  $0.1\mu\text{F}$  for  $C_S$  to local ground.

## RGB Design

We only need to detect the Line Frequency CMV by connecting the three shields in the same circuit as with the NTSC/PAL design (Figure 4).

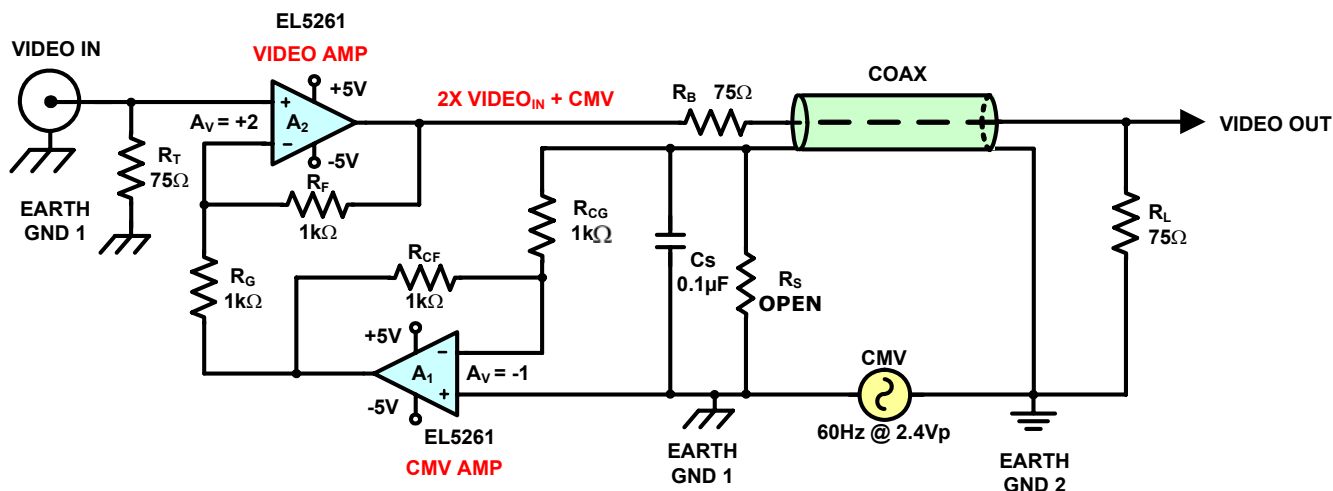

FIGURE 4. NTSC/PAL DESIGN

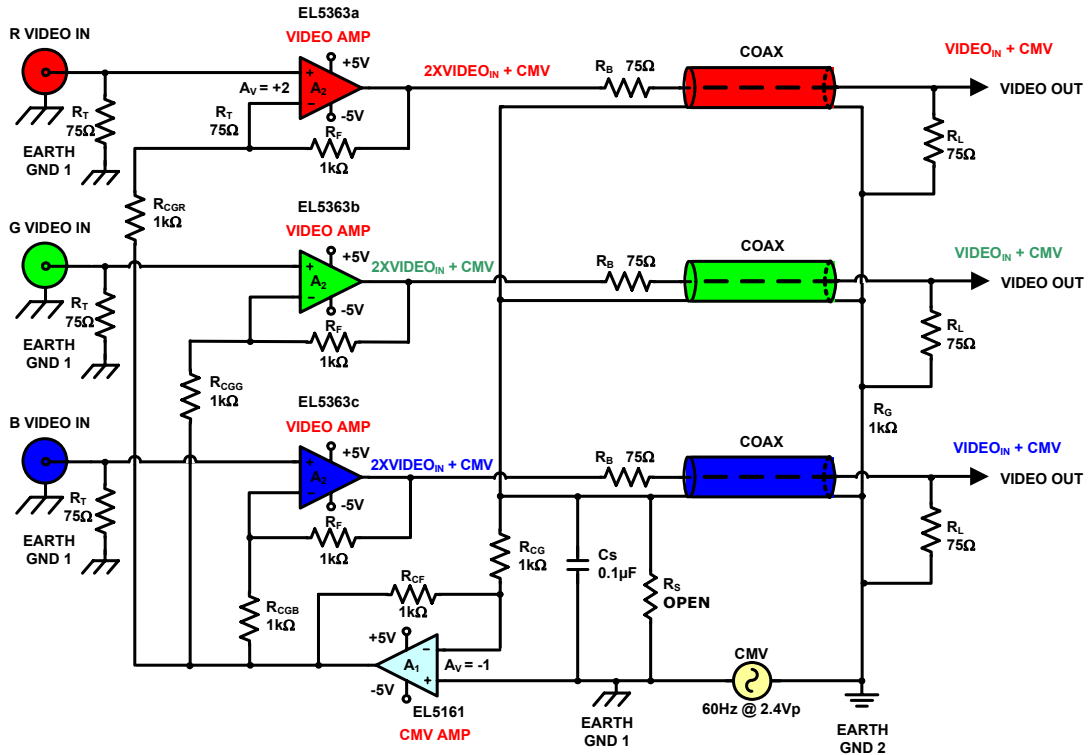

FIGURE 5. COMPLETE RGB TRANSMITTER REJECTION NETWORK

## Test Results from Figure 5 for CMV Cable Driver

### Before Rejection (Figure 6)

Explain: Which circuit did you test to get these results?

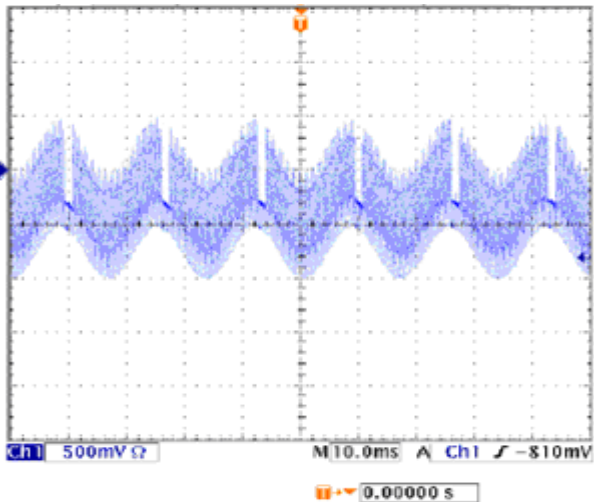

FIGURE 6. VIDEO WITHOUT CMV REJECTION

### After Rejection (Figure 7)

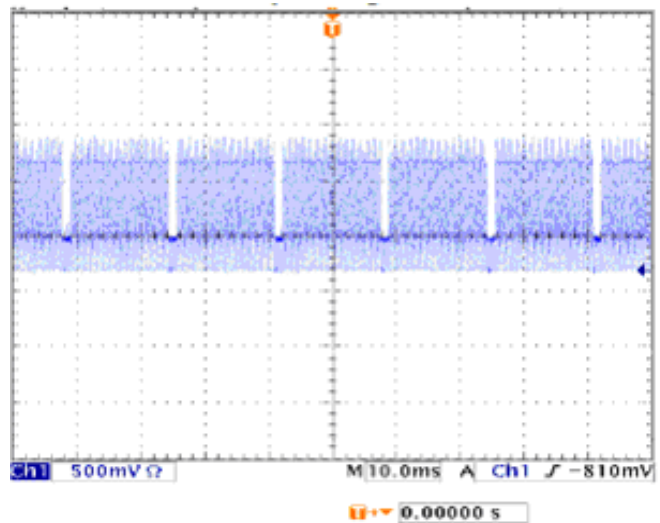
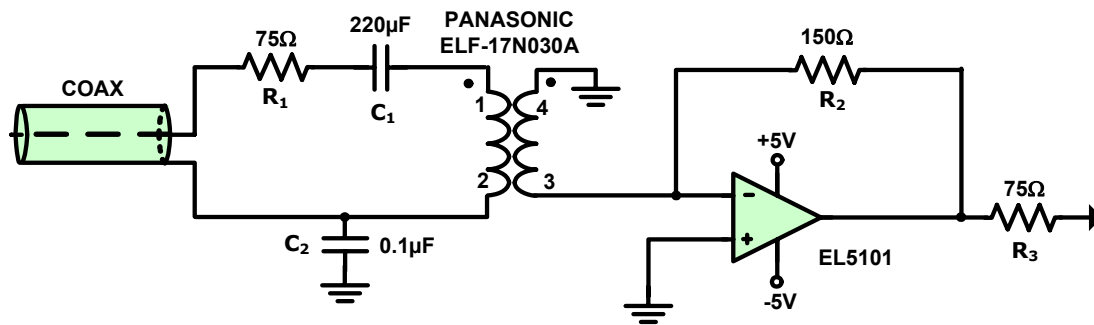

FIGURE 7. VIDEO WITH CMV REJECTION

## VIDEO ISOLATION TRANSFORMER FOR UP TO 120V<sub>AC</sub> CMV

The NTSC/PAL isolation transformer circuit uses a low cost Panasonic ELF-17N030A Iso-transformer in current mode with a voltage mode op amp. The basic circuit is a typical input impedance match with AC-coupling at the front-end (Figure 8). The video is fed to the



**FIGURE 8. DUAL SUPPLY 120V<sub>CMV</sub> - HV ISOLATION TRANSFORMER**

Iso-transformer and to a simple voltage amplifier. In this example, we used the EL5101, a 200MHz Slew Enhanced Voltage Feedback Amplifier (VFA).

### DUAL SUPPLY OP AMP CIRCUIT DETAILS (Figure 8)

The video signal coming into the receiver must be properly terminated to the cable impedance. Since the transformer will appear to the video as a short, we can use the standard 75Ω in series with the primary of the transformer.

Any DC on the incoming video will limit the transformer linearity. This DC can cause early saturation of the core and induce distortion. To block the DC but allow the video, you need a large series capacitor. It is common to use a 220μF coupling capacitor for such applications. The transformer input coupling capacitor, C<sub>1</sub>, may not be needed if there is only a small DC current across the primary winding.

We still need to consider the common mode HF noise that might be present on the incoming signal. Since the Iso-Transformer is a differential receiver, we can easily remove any common mode HF noise by simply connecting the coax shield to the input of the Iso-transformer. Now, connect a 0.1μF ceramic capacitor from the shield/transformer tie point to ground to help to eliminate the HF noise.

### Voltage Mode vs Current Mode Amplifier

Why a voltage mode feedback amplifier (VFBA) and not a Current mode (CFBA) when the Iso-transformer is a current device? The input to the amplifier is effectively 75Ω. The amplifier's gain needs to be 2 to recover the impedance matching loss. The feedback resistor would be 150Ω for a gain of 2. If used with a current mode FBA, this would cause the amplifier to become unstable, as with a gain of two, its gain bandwidth would be in the GHz region and any noise could cause the amplifier to break into HF oscillations.

We need the low impedance to maintain the bandwidth, 0MHz to 5MHz, of the Iso-transformer. Since it is easier to peak the higher frequency, we focused on a transformer with the better low frequency response and with minimal HF loss. The transformer selected has a good response at low bandwidth but a -6dB/Dec roll off

at the high end of the video signal BW. We selected the Isolation Transformer (Panasonic ELF17N030A) for its low input impedance characteristic, good bandwidth and high isolation, up to 120V<sub>AC</sub>.

### Operation

The input and the Iso-Transformer feeds the voltage mode EL5101 forming a gain of 2 with the feedback resistor of 150Ω. The EL5101 gain of 2 has a gain bandwidth of 75MHz, which shows there are more than enough BW, but not so much as to induce instabilities. The amplifier cancels the primary current by driving the secondary winding with a canceling current as it maintains its input delta at 0V. Some small error current will remain as the amplifier's inputs are not perfect and its gain-BW is not perfectly flat over the 0MHz to 5MHz. Yet, the current is small and will not cause saturation of the core, even with a full power signal applied. If you saturate the core, you lose the signal and generate signal distortion.

However, operating the voltage mode FBA in current mode induces heavy loading on the secondary of the transformer since you have a near short on the transformer's secondary. This loading of the secondary will increase the leakage inductance on the primary. This leakage inductance is effectively in series with the input signal. As a series inductance, it will attenuate high frequencies and reduce the bandwidth by about 6dB at 5MHz. This BW loss can be recovered with a peaking network in the feedback loop resulting in a very flat frequency response out to 5MHz.

The peaking circuit needs to be in the feedback loop but also must be isolated from the op amp's output and input (Figure 9). Using two 75Ω series resistors, R<sub>2</sub> and R<sub>3</sub>, to replace the 150Ω effectively isolates the rejection network from the '-' input and output of the EL5101 while maintaining the gain of 2. R<sub>2</sub> + R<sub>3</sub> is 150Ω and functions as the feedback resistor to the amplifier summing node. The R<sub>1</sub> is 75Ω and is the input cable termination and the summing node gain resistor for the op amp.

The peaking circuit needs to add gain at the high end to recover the losses induced by the leakage inductance, -6dB at 5MHz. Connecting the series R<sub>4</sub> (15Ω) and C<sub>3</sub> (1500μF) to ground from the common point, forms the

## Technical Brief 483

RC peaking circuit. This circuit will recover the -6dB and give us a flat response from 0MHz to 5MHz.

### SINGLE SUPPLY OP AMP CIRCUIT DETAILS (Figure 10)

There is a second variation of this design using a single +5V supply for the EL8101 op amp. The coax input to single-ended single supply +5V op amp will require you offset the input to the op amp to prevent clipping. We need to level shift the iso-transformer output to the mid range of the op amp's CMV. If we level shift the iso-transformer off ground to about 2V, the EL8101 amplifier will be able to support unipolar swings. The circuit description is the same as for the dual supply except for the level shifter.

By using a simple voltage divider,  $R_6$  (2k $\Omega$ ) and  $R_7$  (3k $\Omega$ ) from +5V to ground, we can generate a level shift of 2V. To insure stability and not induce more CMV on the input, we bypass  $R_7$  with a large 220 $\mu$ F cap.

NOTE: The previous circuits are DC-coupled but the Iso-transformer is an AC coupling device so the output will always be at the average value of the input signal. Therefore, you cannot expect the sync tip to be at a fixed DC level since the input video signal is asymmetric and has a signal dependant average value. The amplifier output will have a DC level change (300mV for a standard video 1V<sub>p-p</sub> signal) if the input video changes from black to white.

Also, this circuit's output DC level change rate is less than 80mV/ms in order to be compatible with typical DC Clamp circuits.

### TEST RESULTS

The circuit was tested using a signal generator set to 18V<sub>p</sub> at 6MHz with no degradation to the video signal. The actual CMV limitation would be that of the transformer itself, 120V<sub>AC</sub> line. However, the transformer could withstand 1500VP non-repetitive spikes.

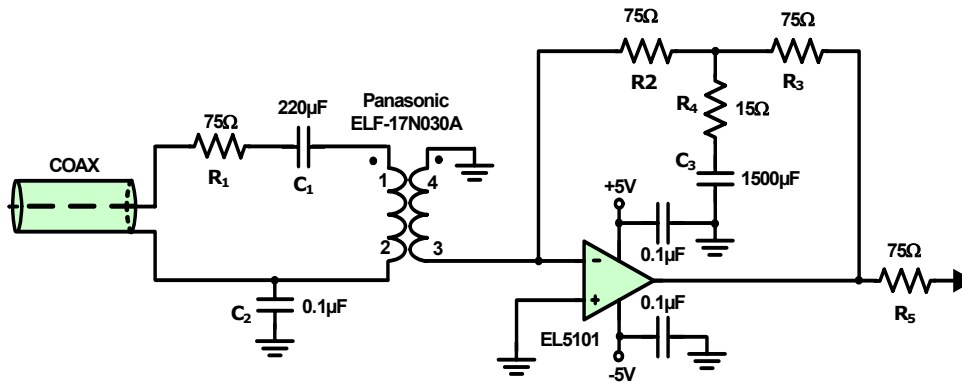

FIGURE 9. DUAL SUPPLY 120V<sub>CMV</sub> - HV ISOLATION TRANSFORMER

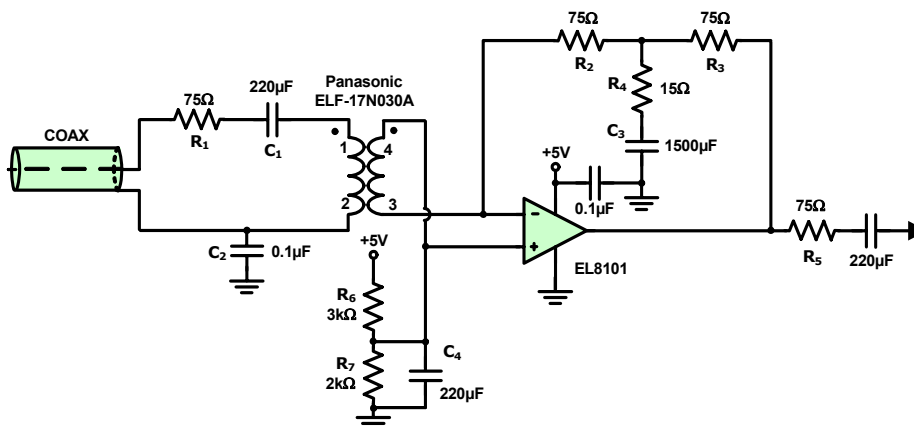

FIGURE 10. COMPLETE SINGLE SUPPLY 120V<sub>CMV</sub> - HV ISOLATION TRANSFORMER

Intersil Corporation reserves the right to make changes in circuit design, software and/or specifications at any time without notice. Accordingly, the reader is cautioned to verify that the Application Note or Technical Brief is current before proceeding.

For information regarding Intersil Corporation and its products, see [www.intersil.com](http://www.intersil.com)