

# Video Cat 5 CMV Rejection Networks

## Introduction

### NTSC/PAL and RGB/KVM

Common Mode Voltage (CMV) requirements vary by application. In the US,  $\pm 3.5V$  of CMV will support most short to medium length cable CMV requirements. For long cables and for Rest Of World (ROW), the ability to support higher CMV ranges are needed. This tech brief will address multiple options for overcoming large CMV ranges in video applications. Let's start with a short prelude to the different types of video and an overview of solutions for CMV.

### Typical Applications

The ISL5960X NTSC cable comp IC can support up to  $\pm 1.5V$  CMV. For higher levels of CMV, a resistor diff-amp, shown in Figure 1, is a low cost solution for NTSC with CMV up to  $\pm 20V$  CMV with additional circuitry. We will discuss these additional circuits in detail.

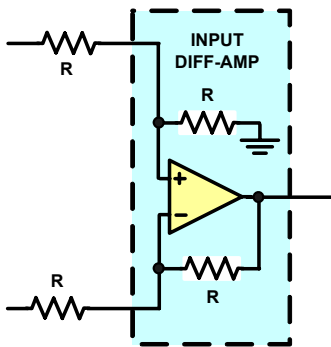

**FIGURE 1. SIMPLE RESISTOR DIFF-AMP CONFIGURATION**

**Passive and Active CMV** - For up to  $\pm 3.5V$  CMV, we would recommend the EL5172/5 differential video amp. Yet, you will find that higher CMV is needed for ROW applications, so an input amp with  $\pm 6V$  to  $\pm 20V$  CMV range is needed. The higher voltage CMV ranges can be realized using passive resistor configuration, as shown in Figure 1. Passive CMV can range from  $\pm 6V$  to  $\pm 12V$ . Adding an active CMV cancellation circuit will increase the CMV to  $\pm 20V$ .

**Video Isolation Transformer** - For even higher CMV, the Video Isolation (ISO) Transformer is an ideal solution in NTSC/PAL applications. We will present a few low cost Video ISO transformer amp designs for Cat 5 cable which offer up to 120V AC line isolation. Use of a video ISO transformer limits the circuit response to a flat 5+MHz. This rules out the ISO transformer in RGB, KVM, and Y Pb Pr applications.

**RGB Video, KVM and Y, Pb, Pr** - The RGB video on Cat 5 cable requires higher bandwidth. For such cases, the EL5375 or EL5378 may be used for  $\pm 3.5V$  CMV. Passive

CMV resistor configured amps are useful in designs for CMV from  $\pm 6V$  to  $\pm 12V$ . Adding the active CMV cancellation circuit will improve the CMV to  $\pm 20V$ . These higher voltage differential amp circuits can be used with a balanced video source. We cannot use a video ISO transformer to support higher CMV, as we did for NTSC/PAL, as the transformer limits the circuit response to a flat 5+MHz. RGB, KVM, and Y Pb Pr applications require fault band response in the 30MHz to 250MHz range.

**Sync on Video lines** - Video cables that have high CMV have problems when used with encoded differential  $H_{SYNC}$  &  $V_{SYNC}$ , such as you will find when using the EL4543 where  $H_{SYNC}$  &  $V_{SYNC}$  is encoded on RGB. As it is difficult to differentiate between the induced CMV you want to eliminate and the encoded  $H_{SYNC}$  &  $V_{SYNC}$  you need. Yet, for high CMV situation, the  $H_{SYNC}$  &  $V_{SYNC}$  can be sent using Sync On Green (SOG), (see Application Note [AN1462](#)), to get around the  $H_{SYNC}$  &  $V_{SYNC}$  CMV problem. With encoded CMV sync, a more complex sync recovery and CMV rejection design is needed but is not offered in this tech brief.

### A Side Bar on Two Types of CMV and Balanced vs Unbalanced Sources

In the video over Cat 5 type of applications, due to a long cable, you will experience more than just the typical CMV. We can group the common mode voltages into two types, which we label 'Hard-CMV' and 'Soft-CMV':

**Hard-CMV:** The distances from the source to the display can have a large local ground difference due to power line common mode voltage. That is to say, the local ground for the camera/video source, most likely, will not be at the same potential as the local ground of the display/video receiver. This is a fixed or what we call "HARD" common mode voltage which can occur even over short distances depending on the local ground potentials. Thus, it is somewhat independent on the cable length and is of low impedance, it is a local ground. This low impedance complicates the removal of the Hard-CMV on the incoming signal from the source, as it cannot be reduced by loading the CMV, so must be rejected by the video receiver. In the ROW, it is common to have up to  $\pm 18V$  of hard CMV.

**Soft-CMV:** Cat 5 is typically not a shielded cable but is a twisted wire pair in a plastic sleeve. The longer the cable, the better the chance of the cable developing common mode voltages due to static and/or noise pickup. This form of CMV is more dependent upon cable length and has higher impedance, which makes it easier to remove from the incoming signal at the receiver by loading the CMV.

This Technical Brief will offer solutions for both Hard-CMV and Soft-CMV.

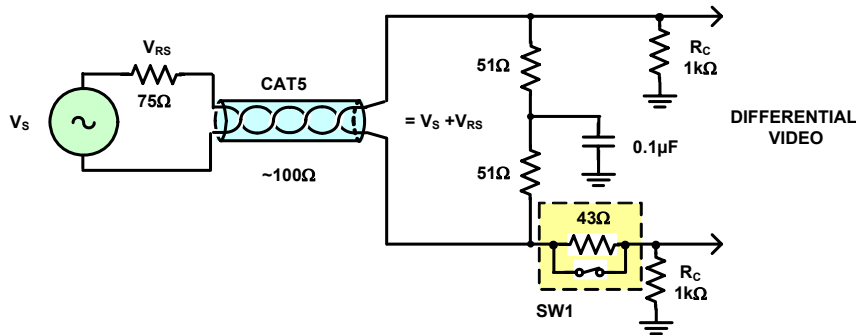

**FIGURE 2. INPUT BLOCK DIAGRAM - CMV, (UNBALANCED SOURCE)**

**Balun vs Active Driven Balanced Sources** - NTSC and PAL are often sent, from the source, by either the cable driver output to a balun/unbalance source impedance of 75Ω or a diff-amp with a balanced source impedance of 51Ω per line on twisted pair. The balanced and unbalanced sources are a significant problem when dealing with CMV reduction and rejection.

### Unbalanced and Balanced

There are two types of Video sources resulting from 1) a Balun unbalanced source and 2) a balanced source.

**Unbalanced** - When the NTSC and PAL video is sourced from a Balun to Cat 5 cables, the video is normally unbalanced. Figure 2 is a typical circuit diagram and is used as inputs to a diff-amp with high CMV input impedance. The single 75Ω source impedance generates an unbalanced source. Any voltage developed across the source series impedance,  $V_{RS}$ , will appear as an unwanted differential voltage at the receiver, called CMV Differential Conversion. In this case, the receive signal is made up of the video signal from the source plus this differential CMV.

$$V_{\text{SIGNAL}} = V_S + V_{RS} \quad (\text{EQ. 1})$$

This is a serious problem because the soft CMV can be very large and with the differential voltage,  $V_{RS}$ , the combined input to the diff-amp can drive the diff-amp input into saturation. You can try loading the incoming signal to reduce the CMV incoming signal, but this will induce more differential conversion. The more the load, the larger  $V_{RS}$  becomes, the larger the differential conversion. One way to deal with this type of CMV loading is by adding a balancing resistor of 43Ω to the receiver input network low side line. The 100Ω is effectively in parallel with the 75Ω on the '+' terminal and looks like 43Ω. By placing the 43Ω on the '-' terminal, you now have a balanced source to the amp (see Figure 2, SW1).

So the source 75Ω loaded with 100Ω termination resistor now gives ~60% of the CMV conversion voltage and the receive side 43Ω now forms a balanced circuit. The switch lets you use this design for both Unbalanced and Balanced circuits. SW1 is closed for balanced and open for unbalanced sources.

An alternate method is to increase the CMV load resistors ( $R_C$ ) to 5kΩ. Increasing load resistors ( $R_C$ ) helps reduce the current through the source resistance and thus, lowering common mode to differential conversion voltage,  $V_{RS}$ . This is effective for wide bandwidth amplifiers where normally you would have a balanced source or where you use the 43Ω balance resistor for an unbalance source.

Increasing  $R_C$  to 5kΩ with 6V<sub>p-p</sub> CMV would give 5.3mV<sub>p-p</sub> differential with no 43Ω balance. The 75Ω source at 5% will have only 3mV<sub>p-p</sub>, which is not a problem as it cannot be seen.

**Balanced** - When a 50Ω 1% balanced source is used then the voltage developed across the generator's series impedance is nearly eliminated. You may see the conversion to differential will be less than 1mV<sub>p-p</sub> with the 43Ω on the receive side shorted out. The two 51Ω in series across the cable input terminate the cable to prevent reflections. The 0.1pF to ground from the mid point reduces the high frequency CMV and does not load the power line hard CMV.

An alternative way to deal with differential CMV is a compromise where no switch is used for easy set up. The compromised resistor would be ~20Ω and would yield ~26mV CMV conversion for both balun and differential inputs. The 26mV would have only a small effect on the display out of 700mV FS, which support NTSC, PAL and wide bandwidth RGB.

### Overview of Cat 5 Cable Receivers

The video diff-amps have ±3.5V of CMV range, which will work for many applications. Some applications require a higher voltage CMV range. We will discuss four designs to address higher CMV.

- 1. Video Amp** - The first video diff-amp has ±3.5V CMV for NTSC, PAL and RGB. We selected the EL5172 (NTSC/PAL) or the EL5375 (RGB) for the differential input video amp.
- 2. NTSC/PAL Video Resistor Diff-Amp with ±6V to ±20V CMV** - The second is a CMOS amp, selected for high input impedance at 50Hz/60Hz. This CMOS amp, EL5111, has a higher impedance input at low frequency to reduce CMV conversion problems. The cancellation circuit does not cause

attenuation of the input signal which is common in CMV cancellation circuits so it does not reduce the performance of the NTSC/PAL signal. Matching 1% on resistor are not adequate to remove all CMV Conversion. You will need a Sync tip clamp or DC restore on the output to remove any residual CMV Conversion voltage caused by resistor mismatch.

- 3. RGB and KVM Video Resistor Diff-Amp with  $\pm 6V$  CMV to  $\pm 20V$  CMV** - The third is a differential input configuration amp. Using resistors and the EL5363, it will offer  $\pm 6V$  CMV with an option to raise the CMV with active cancellation to  $\pm 20V$  CMV and wide bandwidth for RGB Cat 5 cable with a balanced source. Please note that solution 3 is a variation of solution 2 and will be described together noting their difference. As before, the cancellation circuit does not cause attenuation of the input signal, which is common in CMV cancellation circuits so it does not reduce the performance of the RGB signal. Note: unbalanced sources are seldom used in RGB applications but will still have CMV conversation for differential mode caused by resistor mismatch of about 340mV at 20V<sub>P-P</sub> CMV. The back porch clamp will remove this mismatch differential mode CMV.

**Note:** Y, Pb, Pr - Y will have a sync tip but Pb/Pr may or may not have sync tips. This is a special case and may require a sync separator and a DC restore for the Pb and Pr lines. This will not be covered in this tech brief.

- 4. NTSC Video ISOLation transformer** - The fourth is video transformer isolation at 120VAC line rating used with NTSC and PAL. The ISO transformer is a floating load and thus, has very large impedance. The ISO transformer will work with either balanced or unbalanced I<sub>SOURCES</sub> equally as well. The ISO Transformer offers full Galvanic isolation.

## Cat 5 Video Differential Video Cable Receiver Detail Description

- 1.  $\pm 3.5V$  CMV Circuit** - The first circuit, Figure 3, is a Cat 5 to Coax converter with  $\pm 3.5V$  CMV, which relies on the amp's CMV range while converting differential input to single-ended output. We used the EL5172 for NTSC and PAL in a simple unity gain configuration. We can use the same circuit with a higher bandwidth op amp, the EL5375 or EL5378, for RGB video (only the EL5172 circuit is shown for reference). The 55 $\Omega$  resistor right at the input to the amplifier is to reduce possible feedback generated oscillation and should be placed as close to the inputs as possible. Note the ESD clamp diodes location for ESD protection.

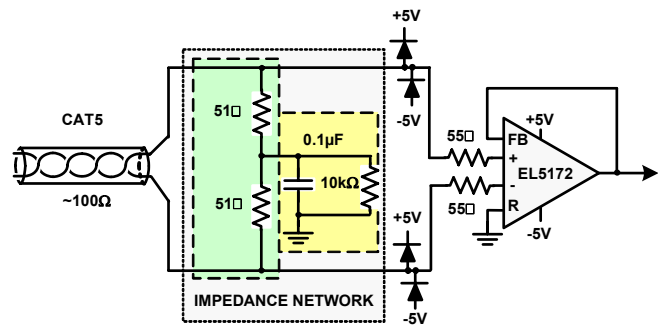

FIGURE 3.  $\pm 3.5V$  CMV CIRCUIT

- 2. NTSC Video Resistor Diff-Amp with  $\pm 6V$  to  $\pm 20V$  CMV** - The second circuit, Figure 4, is based on a CMOS amp, EL5111, using feedback resistors and input series resistors to form the resistor diff-amp. This circuit will increase a typical diff-amp CMV to  $\pm 6V$  CMV.

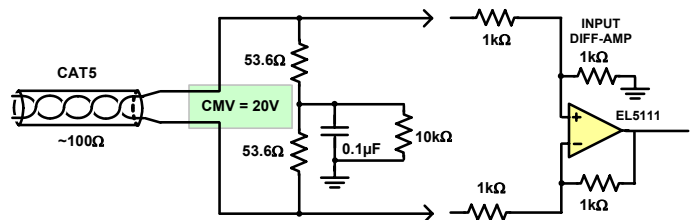

FIGURE 4.  $\pm 6V$  CMV CIRCUIT

### Input Impedance Network with $\pm 6V$ CMV

**Note:** (Figure 4) NTSC/PAL - Why 53.6 $\Omega$  vs 50 $\Omega$ ? To insure Input Impedance is maintained at 100 $\Omega$ . The diff-amp 1k $\Omega$  input and feedback resistors were used for low noise and stable amp operation, yet the input resistors appear as a 1k $\Omega$  load to the cable. To maintain 50 $\Omega$  load to the Cat 5 cable, we change the cable input series termination to 53.6 $\Omega$  and the overall parallel input impedance value is 100 $\Omega$  at high frequency.

**Extending Passively to  $\pm 12V$**  - By adding two CMV attenuator resistors, a simple voltage divider, the CMV range can be increased to  $\pm 12V$ .

**Extending Actively to  $\pm 20V$**  - By adding a second amp, EL5120, to drive the CMV attenuator resistors we can reach  $\pm 20V$  CMV. There will be some CMV conversion on the video so a sync tip clamp must be used to remove it.

### EL5111 Diff-Input First Stage with $\pm 6V$ CMV

The cable drives the first stage, which is a unity gain amp, even though more gain in the first stage gives lower noise but also reduces the maximum CMV range. We can use this first stage to help with Hard-CMV and Soft-CMV rejection and convert from a differential to a single-ended signal.

The incoming video is a differential signal. Using a simple resistor configured differential amplifier will convert the differential input to a single-ended output. We selected

the EL5111 for its low noise and good common-mode voltage range. We configured the EL5111 as the differential to single-ended unity gain amp to take full advantage of its CMV range. Yet, the CMV range of the EL5111 is limited to about  $\pm 5V$ . In this diff-amp configuration, the circuit CMV is  $\pm 6V$  at a gain of one.

**Input Impedance Impact on Bandwidth** - The EL5111 was chosen for the input amp to get a high impedance input to reduce CMV conversion with a balun source. The EL5111 is a CMOS input op amp, so, in this differential resistor configuration, there is no current noise impacting the input signal, and the EL5111 will have sufficient bandwidth to support the needs for NTSC/PAL video.

If we used  $1k\Omega$  to form the diff-amp, the EL5111 will not have sufficient low frequency, high input impedance, but good high frequency bandwidth. What we need is a frequency dependent diff-amp configuration, which offers a large input impedance to the bulk of the CMV. This bulk CMV is typically at the line frequency (50Hz/60Hz), yet, at the higher frequencies, maintains adequate bandwidth to pass any high frequency video content. By design, we found that using  $\sim 50k\Omega$  to form the diff-amp, offered ample low frequency input impedance but rolled off the bandwidth well before needed 5MHz to 6MHz. The input  $51k\Omega$  with the stray capacitance will roll off the input signal to the amp and the stray capacitance will cause the feedback  $51k\Omega$  to lose control of the gain at high frequency. Yet, using  $1k\Omega$  to form the diff-amp, the EL5111 has sufficient high frequency bandwidth to support the 5MHz to 6MHz bandwidth needed for NTSC/PAL.

The series plus input gain network would be a  $51k\Omega$  resistor input and a  $51k\Omega$  to ground. The input to the EL5111 would be half that of the input CMV. We selected the value for these resistors to be  $51k\Omega$  for low CMV conversion load.

When testing, we found that using a  $51k\Omega$  in series with a  $1k\Omega$  and having the  $51k\Omega$  bypassed with  $2200\mu F$  cap works, but to guardband we selected  $4700pF$ . Now we have a flat bandwidth out to 5+MHz for NTSC and PAL video (Figure 5).

**Resistor Inaccuracies Impact on CMV** - Do to the resistor inaccuracy, you can have video which has some 60Hz CMV converted to differential video on the output signal. The input resistor accuracy will cause CMV differential conversion to CMV on video. Using 1% resistors will add about 1% CMV to differential video conversion. These impacts will require the use of a sync tip clamp to reduce the CMV on video output. Using a sync tip clamp can remove up to several volts of differential CMV on video. A sync tip clamp will reduce the CMV on video output by  $\sim 256$  to 1 ratio.

NTSC video is typically an interleaved line scan based on a total of 512 horizontal lines at 60Hz vertical scan rate. So, with interleaving horizontal lines, horizontally you have 256,  $63.5\mu s$ , lines per one cycle of 60Hz. Since the bulk of this error generated by CMV is about 60Hz, then each horizontal video line would have a portion of the 60Hz CMV. To make the math and explanation simple we will assume you have 1V CMV residual on the output video. If you divide the 1V CMV by the 256 line per vertical scan you get 3.6mV or about 4mV/H-line of CMV.

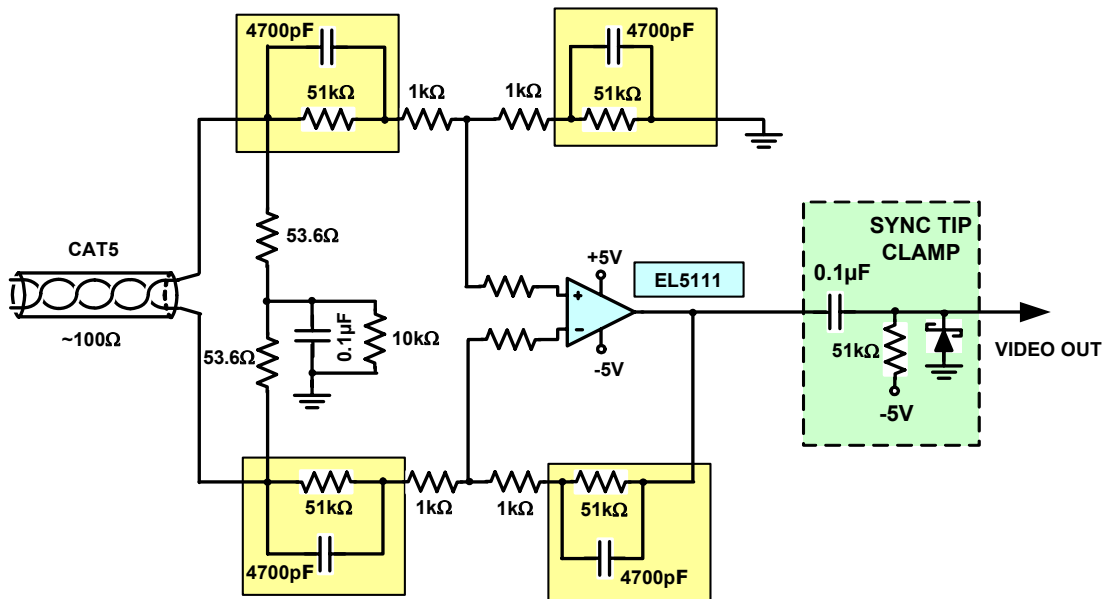

**FIGURE 5. MAINTAINING BANDWIDTH WITH FREQUENCY DEPENDENT INPUT IMPEDANCE CIRCUIT**

**Sync Tip Clamp** - How to compute the RC of the Sync Tip Clamp - If we reset the sync tip to ground at the start of every line (function of the high speed Schottky diode) the maximum differential CMV remaining on the video signal will be this 4mV/H-line CMV. Since you have 63.5µs to charge the series cap to 4mV or so, by selecting a typical coupling cap, say 0.1µF for C, you can compute the pull-up resistor. The pull-up resistor must also take into account the follow-on amplifier input bias current. So, for low input bias current amps, CMOS input amps, you should use something in the area of ~200kΩ. High bandwidth amps, bipolar inputs, will require taking into consideration their input bias current. You can, for all intents and purposes, consider these currents as a current source. So, you can use Equation 2:

$$I = Cdv/(dt) \tag{EQ. 2}$$

Taking into account this added bias current, you will end up with ~50kΩ pull-up.

The noise generated by the EL5111 is so low it cannot be seen on the sync tip. Yet, at very long CAT5 cable length, ~6,000ft or more, the SNR will be such that this noise may have an impact on the video at the receiver.

**EL5111 with CMV Attenuation ±CMV 12V Option (Figure 6)**

A simple voltage divider will raise the allowable CMV by adding the 25.5kΩ resistors to the amp inputs to ground attenuates the CMV at the amp inputs. The 25.5kΩ parallel the 51kΩ to ground gives 17kΩ to ground and with 51kΩ input has a CMV reduction by a factor of 4. So 4 times the allowed amp CMV of ±3V is ±12V CMV range. The CMV conversion to video effect is determined by the ratio error of the resistors. The differential conversion error can be reduced by using resistors with greater accuracy.

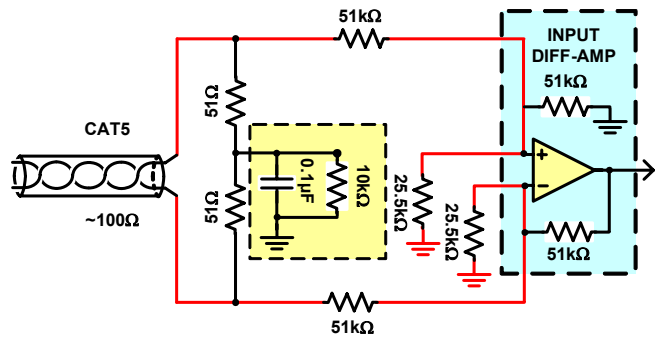

FIGURE 6. EXTENDED CMV TO ±12V CIRCUIT

**±20V CMV Compensation** - You can reach up to ±20V CMV by adding an active cancellation at the input to the diff-amp. This design does not reduce any input signal or add any noise to the input. The Hard-CMV cancellation amp simply takes a portion of the input Hard-CMV, inverts the level and drives cancellation resistors to both inputs to the differential input of the EL5111 thus, cancel out the incoming Hard-CMV (Figure 7).

We use the EL5111 in a classic unity gain differential resistor configuration amp to convert the differential input to a single-ended output. The input from the Cat 5 cable will have some value of CMV. If we consider PAL at up to 18V CMV, then we know the CMV cancellation amp would need to attenuate 20V down to about 5V or a ¼th gain.

To extend the CMV range of the EL5111, we will need to cancel out or reduce this Hard-CMV level, such that the input to the EL5111 sees no more than about 3V of any type CMV.

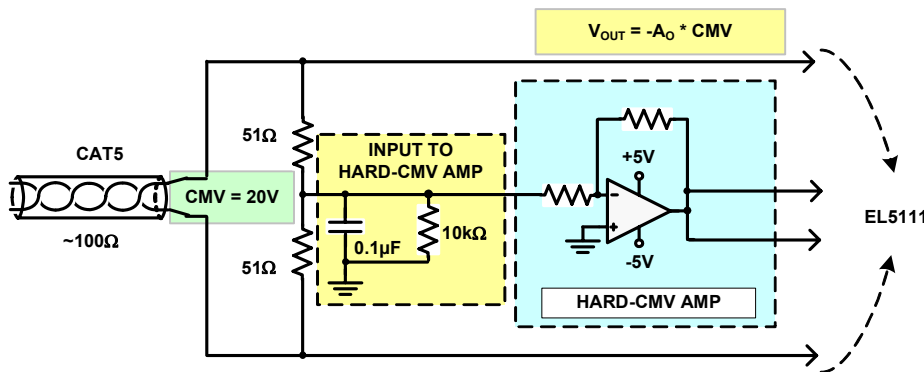

FIGURE 7. CMV ACTIVE CANCELING TO ±20V OPTION

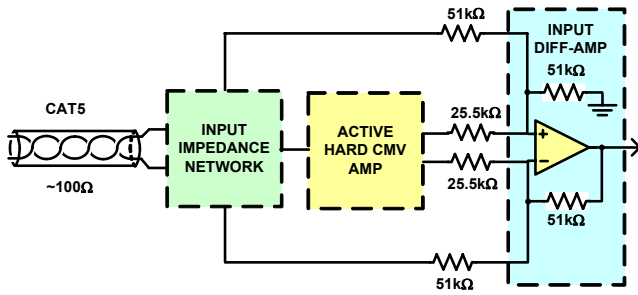

FIGURE 8. COMPLETE CMV ACTIVE CANCELING BLOCK

We selected the EL5120 as the Hard-CMV cancellation amp for its low noise and wide output swing. The inversion subtracts a portion of the Hard-CMV from the cable at the input to the diff-amp. In this manner, we extend the CMV range of the EL5111 by the ratio of the input gain resistors to the EL5120 output drive resistors. We need to limit the overall output from the EL5120 by using a gain resistor at its input to ensure we do not exceed the EL5120 output voltage range as well as the EL5111 input CMV range.

**Input CMV**

The CMV cancellation amp gain is set by simply using the same 25.5kΩ resistor (help reduce the BOM's component count) in the feedback. With the input CMV at 20V, we

need to drive -4.8V at the output of the EL5120 to drive the 25.5kΩ cancellation resistors and keep the CMV of the EL5111 at 3V. We need to calculate the input series resistor to set the gain of the EL5120. If we take the EL5120 feedback 25.5kΩ and multiply it by the ratio of the input CMV to the output voltage, 20V/4.8V, the ratio is ~4. Now multiply the feedback resistor by ~4 and you have an input resistor value of 107kΩ.

**RGB and KVM Video Resistor Diff-Amp with ±6V CMV to ±20V CMV**

EL5111 at unit gain is 60MHz and the circuit is a gain of two is 30MHz and good for NTSC/PAL/YPrPb but not for RGB/KVM which needs over 200MHz bandwidth. The EL5163 wide bandwidth amp, 500MHz Unity gain BW. At a gain of 2 is 250MHz BW, which is more than enough for RGB/KVM.

The NTSC and KVM diff-amp CMV rejection circuits are so much alike so for KVM, reference the NTSC version for a detailed description of the operation.

Why the 5.1k series resistor (Figure 10, R<sub>1</sub> and R<sub>2</sub>)? The RGB high CMV amp needs higher input impedance at 50Hz to 60Hz to prevent excess CMV current load. The peak CMV current is now 3.3mA per each input line for a total of 6.6mA of CMV current.

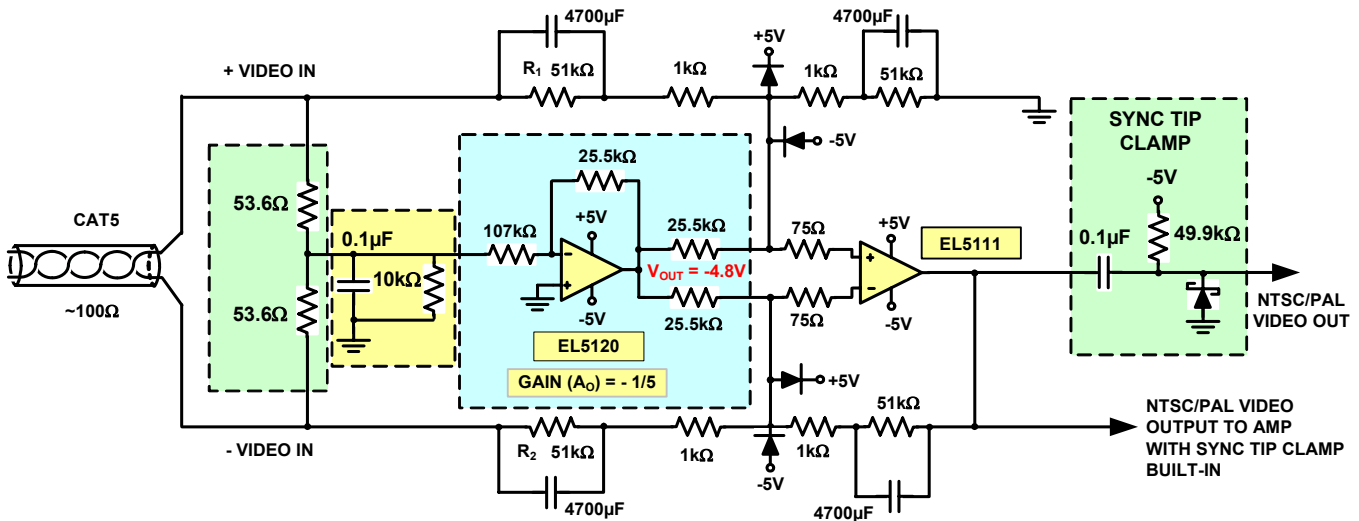

FIGURE 9. COMPLETE NTSC/PAL ACTIVE CMV CANCELLATION W/SYNC TIP CLAMP

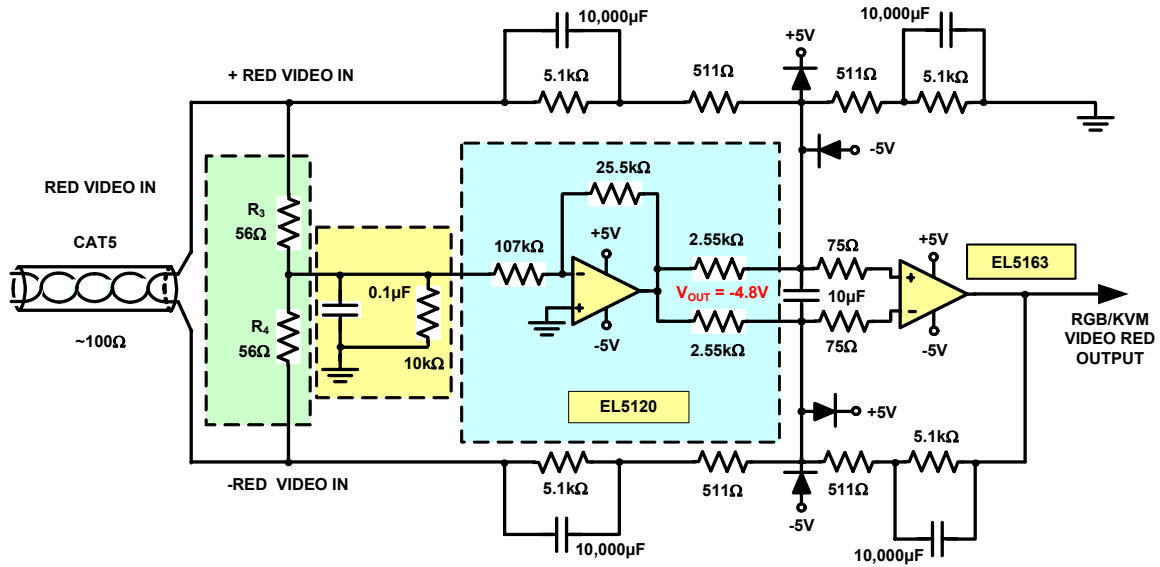

FIGURE 10. RED OF RGB/KVM ACTIVE CMV CANCELATION

**Note:** (Figure 10,  $R_3$  and  $R_4$ ) RGB/KVM - Why 56Ω vs 50Ω? To insure Input Impedance is maintained at 50Ω. For the same reason as in Figure 4, we change the cable input series termination to 56Ω and the overall parallel input impedance value is 50Ω at high frequencies.

**RGB Active CMV Canceling**

We only show one channel, RED, for each of the active CMV cancelation networks, yet, you have RG and B channels. Thus, you will need to triplicate these designs. You can reduce the necessary circuitry by simply having one CMV cancelation amplifier for the RGB receivers.

Since we cannot tie the sources together, we simply use a summing input, one from each RG and B signals, then we can buffer out using three differential outputs. We need to keep the gain the same, so the 25.5kΩ feedback resistor would need to change to  $25.5k\Omega/3 = 8.5k\Omega$  as shown in Figure 11. Since we sum the inputs to use a single amplifier, we drive the three sets of CMV cancelation resistors simultaneously.

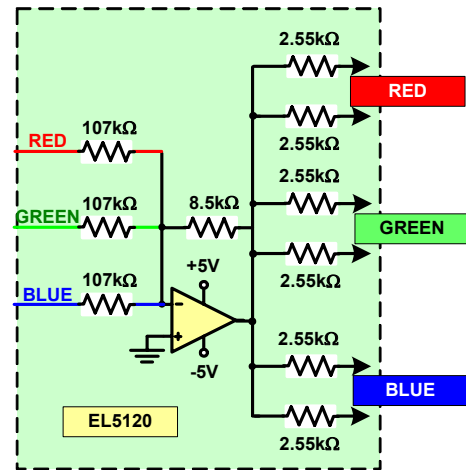

FIGURE 11. RGB COMMON ACTIVE CMV CANCELATION NETWORK

**Video Isolation Transformer**

NTSC and PAL video ISO Transformer to 120V AC. The fourth method for large CMV on NTSC and PAL is transformer isolated. This is using a low cost line filter coil with an amp as a current mode transformer. Without compensation networks, this configuration causes heavy loading on the secondary which in turn causes the leakage inductance to reduce the bandwidth by about -6dB at 5MHz. The use of compensation networks in the amp feedback results in a very flat frequency response to 5+MHz.

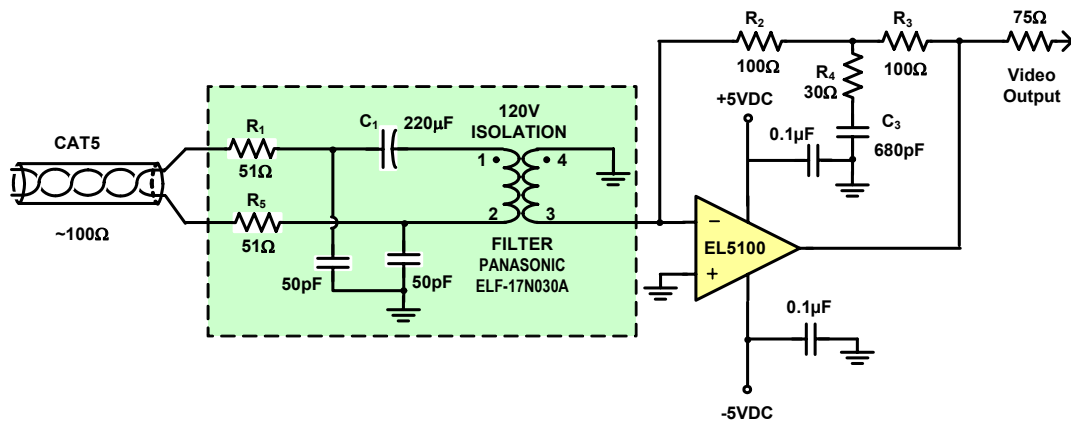

FIGURE 12. NTSC/PAL VIDEO ISO TRANSFORMER CAT 5 TO COAX

**Video ISO Transformer Cat 5 to Coax**

**Circuit Details (Figure 12)** - The Cat 5 cable 51Ω series input resistors functions as the cable termination and gain resistor to the amp summing node and the two 100Ω in series or 200Ω are the feedback resistors and sets the gain at two. The reason for two series resistors is to establish a node for the compensation network. The 100Ω resistors isolate the feedback compensation network from being connected directly to the '-' input or the output of the EL5100.

The transformer is an AC coupling device, so the output will always be at the average value of the input signal. The video signal is asymmetric, so the output will have a changing average value. Note: The sync tip can change its level by 300mV for a 1V<sub>p-p</sub> signal. The maximum rate of change for the ISO Transformer is about 80mV per 1ms, which is much the same as a typical capacitor coupled NTSC/PAL video circuit.

**Voltage Mode vs Current Mode Amplifier**

Why a Voltage Mode Feedback Amp (VFBA) and not a Current Mode Feedback Amp (CFBA) when the ISO transformer is a current device? The input to the amp is effectively 100Ω. The amp's gain needs to be 2 in order to recover the impedance matching loss. The feedback resistor would be 200Ω for a gain of 2. If used with a current mode FBA, it would cause the amp to become unstable (as with a gain of two), its gain bandwidth would be in the GHz region and any noise could cause the amp to break into HF oscillations.

The ISO transformer needs low impedance to maintain the high frequency bandwidth, 0MHz to 5MHz. Since it is easier to peak the higher frequency, we focused on a transformer with the better low frequency response and with minimal HF loss. The transformer selected has a good response at low bandwidth but a -6dB/Dec roll off at the high end of the video signal BW. We selected the ISO Transformer (Panasonic ELF17N030A) for its low input impedance characteristic, good bandwidth and high isolation, up to 120AC.

**Operation**

The input and the ISO Transformer feeds the voltage mode EL5100 forming a gain of 2 with the feedback resistor of 200Ω. The EL5100 gain of 2 to has a gain bandwidth of 75MHz, so, we have more than enough BW but not so much as to induce instabilities. The amp cancels the primary current by driving the secondary winding with a canceling current as it maintains its input delta at 0V. Some small error current will remain as the amplifier's inputs are not perfect and its gain BW is not perfectly flat over the 0MHz to 5MHz. Yet the current is small and will not cause saturation of the core even with a full power signal applied. If you saturate the core you lose the signal and generate signal distortion.

Operating the voltage mode FBA in current mode induces heavy loading on the secondary of the transformer, as you have a near short on the transformer's secondary. This loading of the secondary will increase the leakage inductance on the primary. This leakage inductance is effectively in series with the input signal. As a series inductance, it will attenuate high frequencies and reduces the bandwidth by about -6dB at 5MHz. This BW loss can be recovered with a peaking network in the feedback loop resulting in a very flat frequency response out to 5+MHz.

The peaking circuit needs to be in the feedback loop but also must be isolated from the op amp's output and input (Figure 12). Using two 100Ω series resistors, R<sub>2</sub> and R<sub>3</sub>, effectively isolates the compensation network from the '-' input and output of the EL5100 while maintaining the gain of 2. R<sub>2</sub> and R<sub>3</sub> are 100Ω and functions as the feedback resistor to the amp summing node, while R<sub>1</sub> and R<sub>5</sub> are 51Ω and are the input cable termination and the summing node gain resistor for the op amp.

The peaking circuit needs to add gain at the high end to recover the losses induced by the leakage inductance, -6dB at 5MHz. Connecting the series R<sub>4</sub> (30Ω) and C<sub>3</sub> (680pF) to ground from the common point forms the RC peaking circuit. This circuit will recover the -6dB and give us a flat response from 0MHz to 5MHz.

**Three Variations** - We have three designs; two require  $\pm 5V$  supplies. In general, the transformer input is capacitively coupled using a  $220\mu F$  (C1) cap to prevent core saturation and may not be needed if there is only a small DC current across the primary winding. For high energy ESD protection, you need protection at the inputs of the op amp. Something like MOVs would suppress ESD strikes if placed at the Cat 5 cable input.

The three designs are:

1. Cat 5 cable differential input to single-ended coax output.
2. Cat 5 cable differential input to single-ended coax output with single 5V supply.
3. Cat 5 cable differential input to Cat 5 cable differential output.

**Design 1 (Figure 12)** - This design supports a Cat 5 cable input to single-end coax output. The Cat 5 cable input design uses two input termination  $51\Omega$  resistors and one capacitor in series with the transformer input, as noted before, to prevent core saturation due to DC currents. The ISO Transformer output has one side of the secondary connected to ground and the other side to the amp summing node. The feedback is now two  $100\Omega$  series, which generates a gain of 2 and the  $75\Omega$  to the output cable gives a gain of 1 at the receive cable input.

**Design 2 for a Single Supply Amplifier (Figure 13)** -

If you select a single supply amplifier, it is necessary to select one with a rail-to-rail output. At 5V supply you need to support the  $2V_{p-p}$  NTSC/PAL video signal. We selected the EL8101 rail-to-rail output op amp. It has ample bandwidth and is rail-to-rail output. All we need is to offset the transformer secondary and amplifier ground reference by 2V using a simple  $2k\Omega$  to  $3k\Omega$  voltage divider. The  $220\mu F$  is to offer the required AC ground to the video.

**Design 3 for a Dual Supply Amplifier. (Figure 14)** -

The Cat 5 cable input design uses two input termination  $51\Omega$  resistors and one capacitor in series with the transformer input, as noted before, to prevent core saturation due to DC currents. We need the output to be a differential output, so the secondary winding goes to the summing node of two amps that have compensation networks in their feedback. The op amp outputs from the differential driver. Yet, the feedback resistors are two  $51\Omega$  in series ( $R_5$  and  $R_6$ ) to give a gain of one on each side for a differential amplifier yielding a total gain of two. The output on the cable is terminated with the  $51\Omega$  series resistors, which give 1V differential on the output as is the input signal. The need for the split  $100\Omega$  is to give us an isolated point to add the bandwidth compensation network of the  $10\Omega$  ( $R_7$ ) in series with the  $1500pF$  (C1) to ground. This recovers the operational bandwidth to the necessary 6MHz as previously stated.

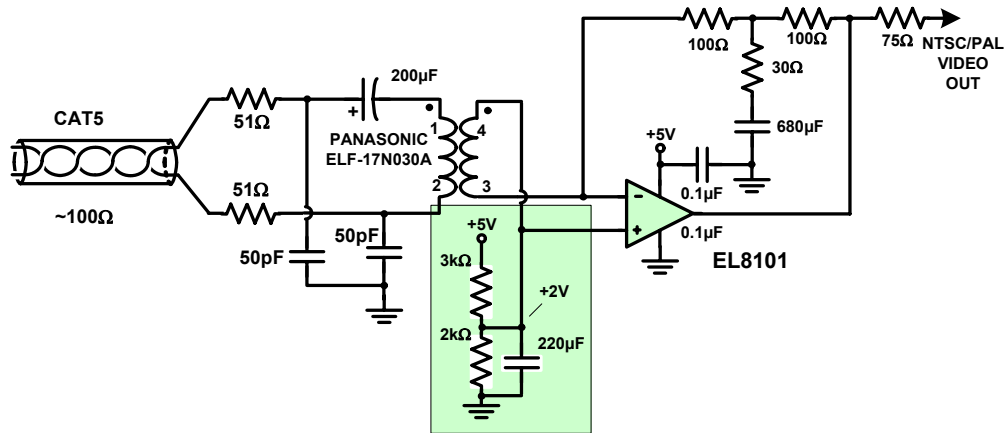

**FIGURE 13. VIDEO ISO TRANSFORMER WITH SINGLE SUPPLY OP AMP**

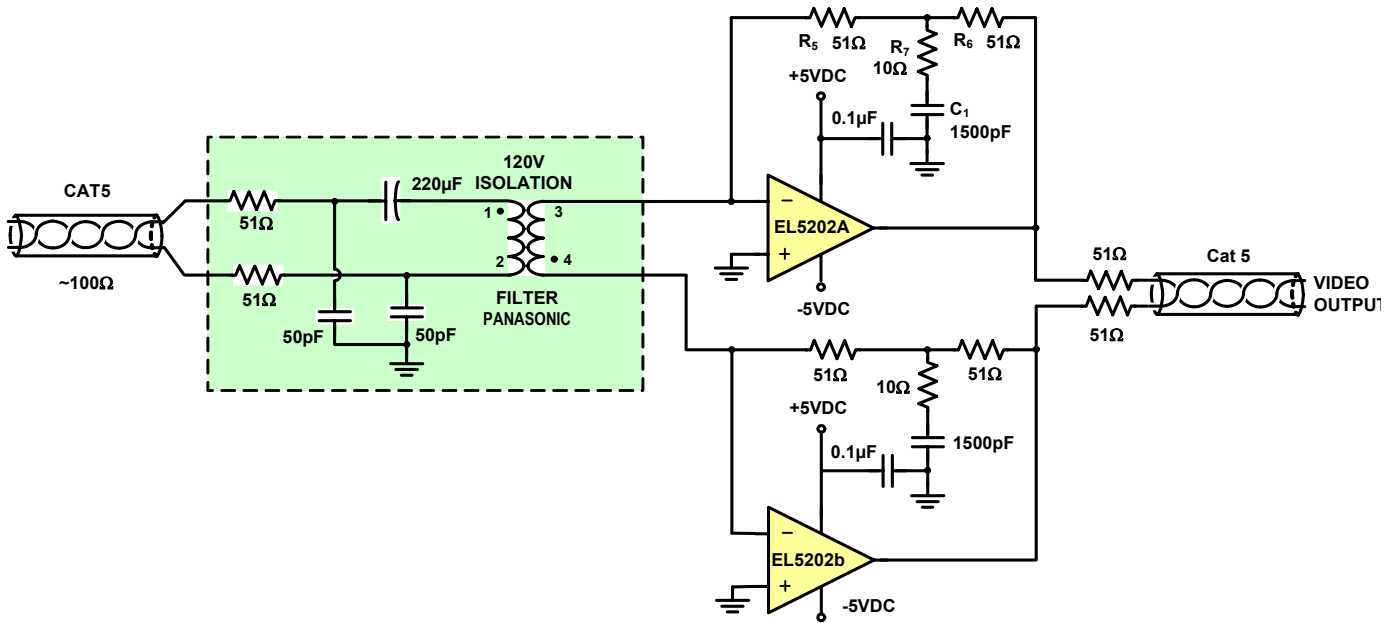

FIGURE 14. VIDEO ISO TRANSFORMER CAT 5 CABLE I/O

**General Point on ESD Protection**

The receiver may need to be protected against ESD strikes, while impedance matching the Cat 5 cable to prevent reflections. As shown in the final test schematic (Figure 15), we selected MOVs to not only help with ESD strikes but also not to impact the cable impedances. We would recommend SNBH65CA at the input connector and BAT54S near the input to the amplifier for good ESD Protection.

**Testing**

To do a rigorous testing of the design, we needed to use long cables. Long cables will greatly attenuate the video signals making it a difficult test for the CMV networks. We added a recovery/peaking network after the CMV networks to recover the signal so we could evaluate

these networks. To complete the evaluation, the CMV must be dealt with first. Then recovery of the video using peaking networks are used to view the video. The test schematic used is shown in Figure 15 with the CMV networks shown to the left of SW20 and the sync tip clamp right after SW20. The test circuit uses a plus going sync so to use a minus going sync reverses the Cat 5 cable inputs and the sync tip clamp diode and the pull-down resistor goes to minus 5V. Both modes were tested.

**Test Results**

The following are the test results for the indicated circuitry figures. The top trace is the CMV signal with the video riding on the trace. The bottom trace output of each of the figures after removal of the CMV.

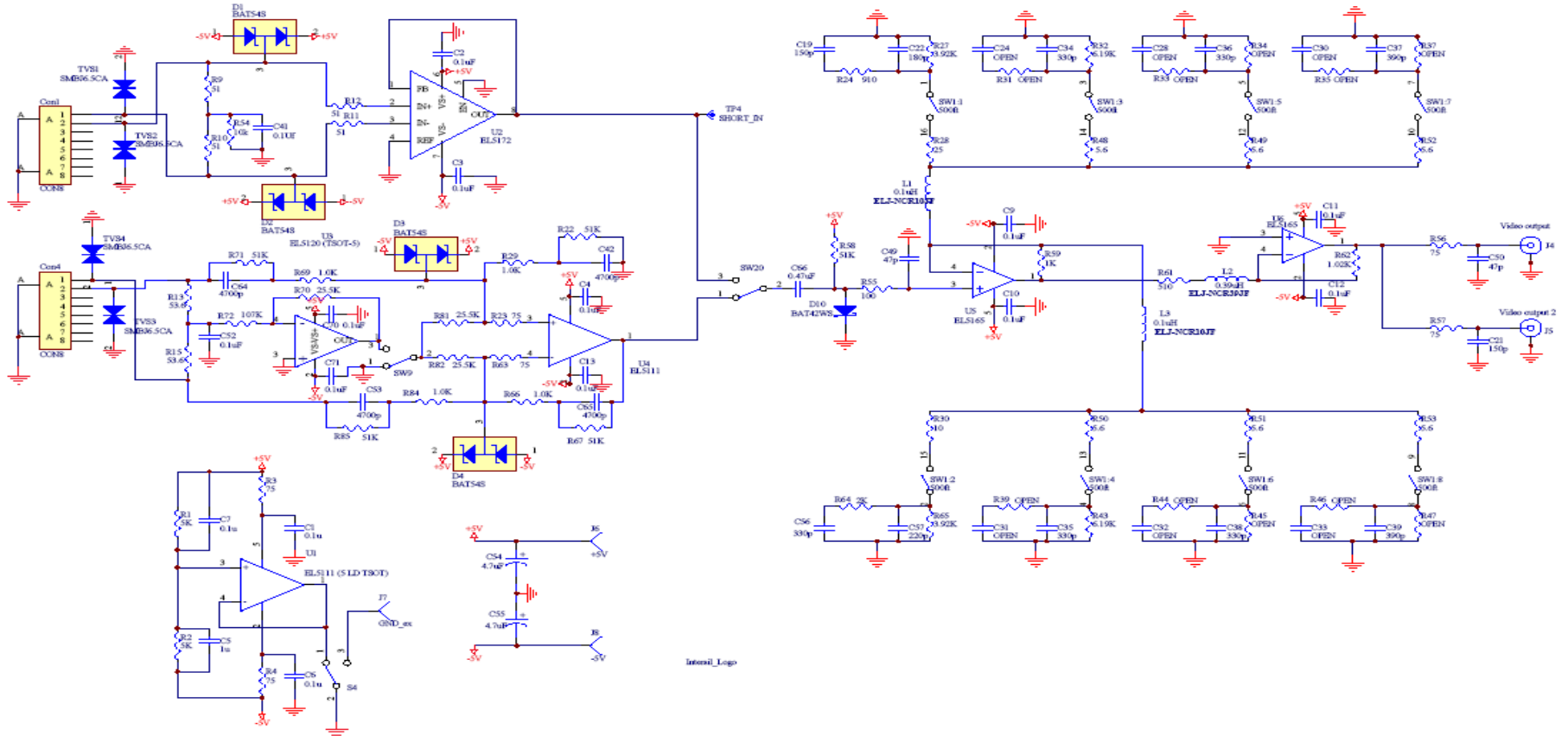

**FIGURE 15. COMPLETE EVALUATION SCHEMATIC**

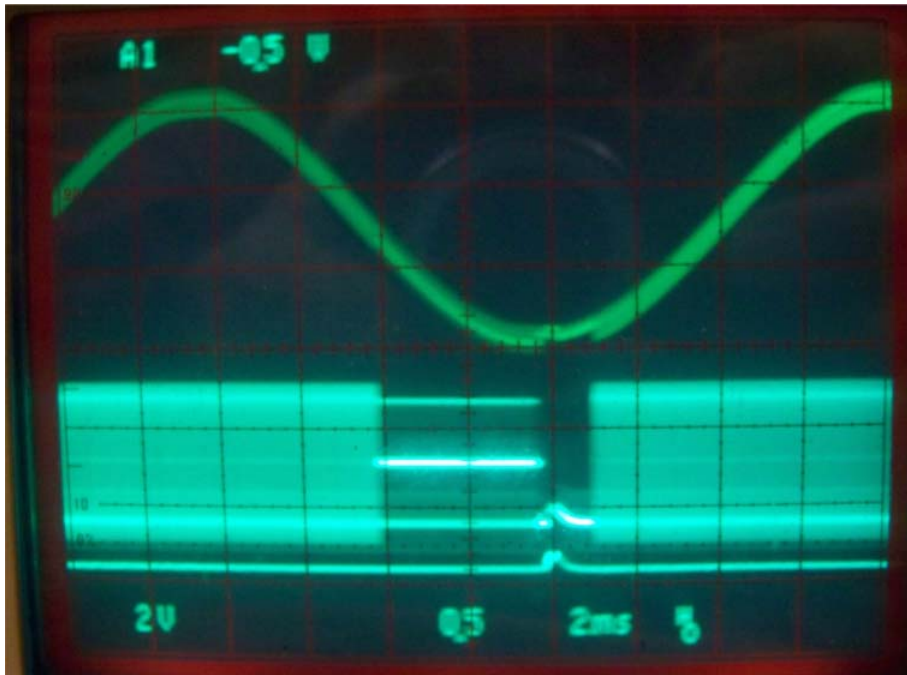

FIGURE 16. NTSC TEST RESULTS FROM FIGURE 3 USING EL5172 WITH  $\pm 3V$  CMV

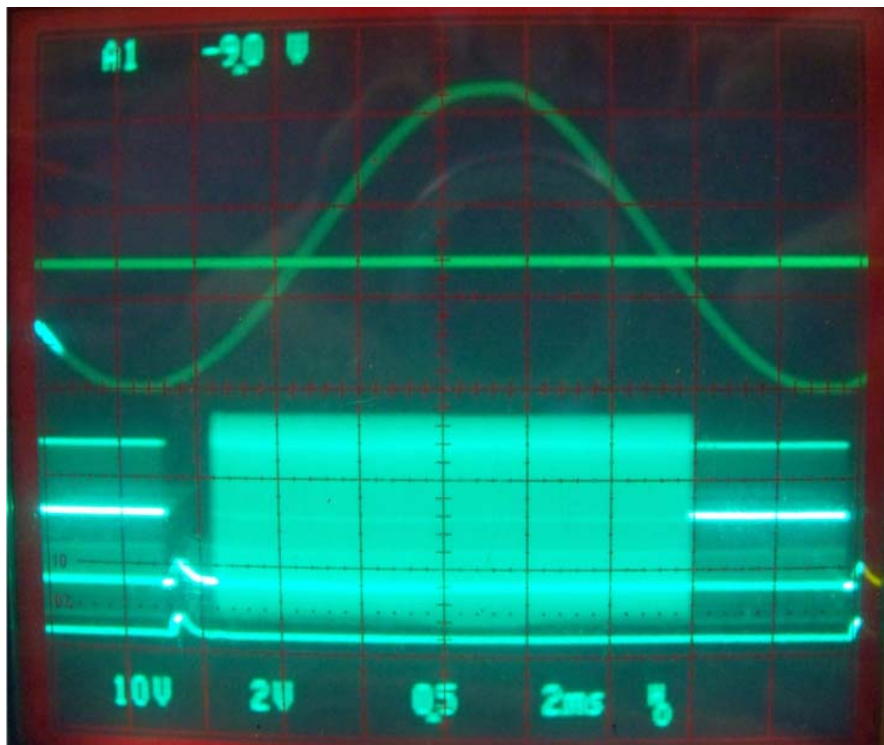

FIGURE 17. NTSC TEST RESULTS FROM FIGURE 9 USING EL5120 ACTIVE CMV AND EL5111 WITH  $\pm 17V$  CMV

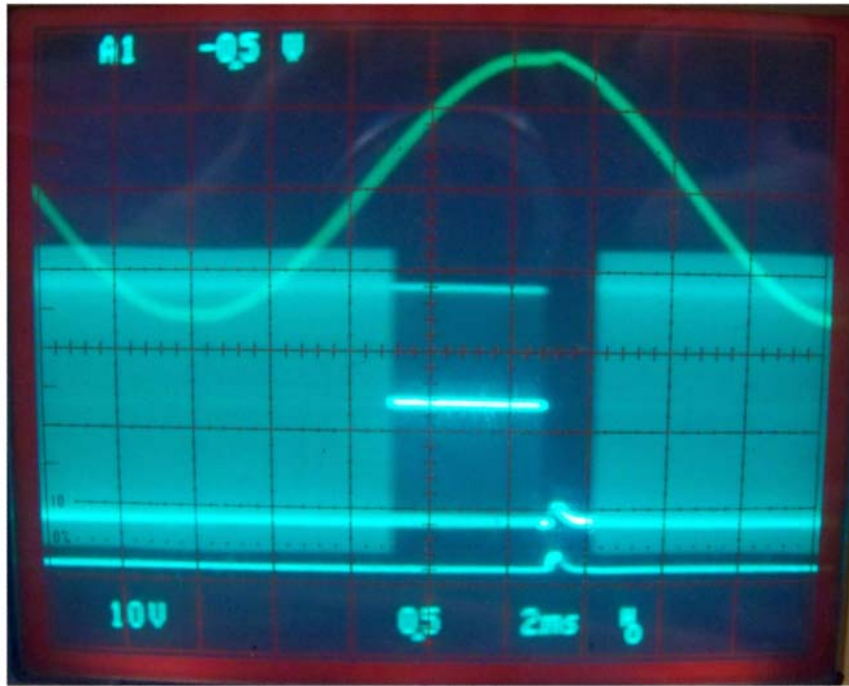

FIGURE 18. RGB TEST RESULTS FROM FIGURE 10 USING EL5172 WITH  $\pm 17V$  CMV

*Intersil Corporation reserves the right to make changes in circuit design, software and/or specifications at any time without notice. Accordingly, the reader is cautioned to verify that the Application Note or Technical Brief is current before proceeding.*

For information regarding Intersil Corporation and its products, see [www.intersil.com](http://www.intersil.com)